

**SECTOR II traffic barrier
Installation manual**



SECTOR II



Company profile



**In-house
R&D
development
team**

**Manufactures to
international
quality standard
ISO 9001:2008**

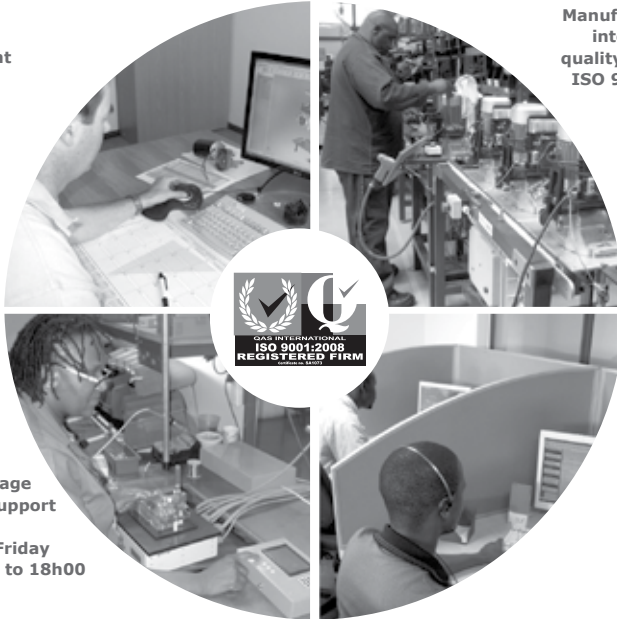

**After-sales
multi-language
Technical Support**

**Monday to Friday
from 07h00 to 18h00
UTC+2
Saturdays
08h00 to 16h30 UTC +2**

**100%
testing of
products**



**Sales and technical support
to Africa, Europe, Asia,
the Americas, Australia
and the Pacific**

Centurion Systems (Pty) Ltd reserves the right to make changes to the products described in this manual without notice and without obligation to notify any persons of any such revisions or changes. Additionally, **Centurion Systems (Pty) Ltd** makes no representations or warranties with respect to this manual. No part of this document may be copied, stored in a retrieval system or transmitted in any form or by any means electronic, mechanical, optical or photographic, without the express prior written consent of **Centurion Systems (Pty) Ltd**.



Contents

SAFETY FIRST

IMPORTANT SAFETY INSTRUCTIONS

page 5

1. Glossary of terms	page 7
2. Product identification	page 8
2.1 Internal components	page 8
2.2 External components	page 9
2.3 Electronics tray	page 9
2.4 Hardware unpacking	page 10
3. Physical installation	page 11
3.1 Preparation of the cabinet plinth	page 11
3.2 Mounting the cabinet	page 12
3.3 Fitting and levelling the boom pole	page 14
4. Onsite electrical wiring	page 17
4.1 AC and DC power isolation	page 17
4.2 Earthing the unit	page 18
4.3 Wiring AC power to the SECTOR II Traffic Barrier	page 18
4.4 Installing loop detectors	page 19
4.4.1 Installing a single FLUX SA loop detector	page 19
4.4.2 Installing dual FLUX SA loop detectors	page 21
5. Basic controller setup	page 23
5.1 Powering up the SECTOR II	page 23
5.2 Programming the controller	page 23
6. Installation handover	page 27
7. Advanced controller setup	page 29
7.1 Menu navigation map	page 30
Installation flow diagram: Center-fold pull-out	page 39
8. Maintenance	page 47
9. Troubleshooting	page 48
9.1 Diagnostics	page 48

10. Appendices	page 51
10.1 SECTOR II specifications	page 51
10.1.1 Unit specifications	page 49
10.1.2 Barrier boom pole specifications	page 52
10.1.3 Fuse protection	page 52
10.1.4 Certificate of compliance	page 53
10.2. Changing the SECTOR II to a left-hand configuration	page 54
10.3 Adjusting limits for Fail-safe Mode	page 60
10.4 11-pin loop detector installations	page 61
10.4.1 Installing a single FLUX 11-pin loop detector	page 63
10.4.2 Installing dual FLUX 11-pin loop detectors	page 65
10.5 Safety beam installation	page 67
10.6 Wiring diagrams for installation modes	page 68
10.6.1 Simplex Mode	page 68
10.6.2 Complex Mode (Option 1)	page 69
10.6.3 Complex Mode (Option 2 - Ticket vendors)	page 70
10.6.4 Uni-directional traffic	page 71
10.6.5 Bi-directional traffic	page 71
10.7 Factory Default Settings (South Africa only)	page 72
10.8 Terminal descriptions	page 74
10.9 Ancillary installation equipment	page 76

Icons used in this manual



This icon indicates tips and other information that could be useful during the installation.



This icon denotes variations and other aspects that should be considered during installation.



This icon indicates warning, caution or attention! Please take special note of critical aspects that MUST be adhered to in order to prevent injury.



This icon indicates areas where mechanical crushing may occur

IMPORTANT SAFETY INSTRUCTIONS

ATTENTION

To ensure the safety of people and possessions, it is important that you read all the following instructions.

Incorrect installation or incorrect use of the product may cause serious harm to people and / or property.



The installer, being either professional or DIY, is the last person on the site who can ensure that the operator is safely installed, and that the whole system can be operated safely.

Warnings for the installer

CAREFULLY READ AND FOLLOW ALL INSTRUCTIONS before beginning to install the product.

- All installation, repair, and service work to this product must be carried out by a suitably qualified person
- Do not activate your barrier unless you can see it and can determine that its area of travel is clear of people, pets, or other obstructions
- **NO ONE MAY CROSS THE PATH OF A MOVING BARRIER.** Always keep people and objects away from the barrier and its area of travel
- **NEVER LET CHILDREN OPERATE OR PLAY WITH THE BARRIER CONTROLS**
- Secure all easily-accessed barrier controls in order to prevent unauthorised use of the barrier
- Do not in any way modify the components of the automated system
- Do not install the equipment in an explosive atmosphere: the presence of flammable gasses or fumes is a serious danger to safety
- Before attempting any work on the system, cut electrical power to the operator and disconnect the batteries
- The mains power supply of the automated system must be fitted with an all-pole switch with contact opening distance of 3mm or greater. Use of a 5A thermal breaker with all-pole circuit break is recommended
- Make sure that an earth leakage circuit breaker with a threshold of 30mA is fitted upstream of the system
- Never short-circuit the battery and do not try to recharge the batteries with power supply units other than that supplied with the product, or manufactured by Centurion Systems (Pty) Ltd
- Make sure that the earthing system is correctly constructed, and that all metal parts of the system are suitably earthed

- Safety devices must be fitted to the installation to guard against mechanical movement risks, such as crushing, dragging and shearing
- It is recommended that at least one warning indicator light be fitted to every system
- Always fit the warning signs visibly to the inside and outside of the barrier
- The installer must explain and demonstrate the manual operation of the barrier in case of an emergency, and must hand over the user guide to the user
- Explain these safety instructions to all persons authorised to use this barrier, and be sure that they understand the hazards associated with traffic barriers
- Do not leave packing materials (plastic, polystyrene, etc.) within reach of children as such materials are potential sources of danger
- Dispose of all waste products like packing materials, worn-out batteries, etc. according to local regulations
- Always check the obstruction detection system and safety devices for correct operation
- Neither Centurion Systems (Pty) Ltd, nor its subsidiaries, accepts any liability caused by improper use of the product, or for use other than that for which the automated system was intended
- This product was designed and built strictly for the use indicated in this documentation. Any other use, not expressly indicated here, could compromise the service life/operation of the product and/or be a source of danger
- Anything that has not been specified in these instructions may be considered a risk to your safety, and the safety of others. If you are unsure of an installation matter, please contact your nearest distributor



1. Glossary of terms

SECTOR II	3, 4.5 or 6m traffic barrier manufactured by Centurion Systems (Pty) Ltd
Boom	Aluminium pole used to close off roadway or section thereof
Loop	Inductive loop manufactured to sense a vehicle when it passes over the loop. Minimum 2.5m wide by 1m
Counterbalance assembly	A spring-assembly to balance the boom pole
Hold down bracket	Bracket used to clamp the cabinet in position
CP84 SM 2A Charger	Battery charger
Camlock	Cabinet-type lock, (60198 Keyed-alike)
DIP switch	Selectable binary switches (two-position)
Modes of Operation	Selection that dictates how the SECTOR II barrier will react to external stimuli
Duty cycle	Percentage per unit time within which the barrier can operate, i.e. 48 minutes in an hour
Collision-sensing operation	The ability of the boom to detect an obstruction and reverse direction
Manual Operation	Allows emergency manual operation of boom without utilising the manual-override

TABLE 1

2. Product identification

2.1 Internal components

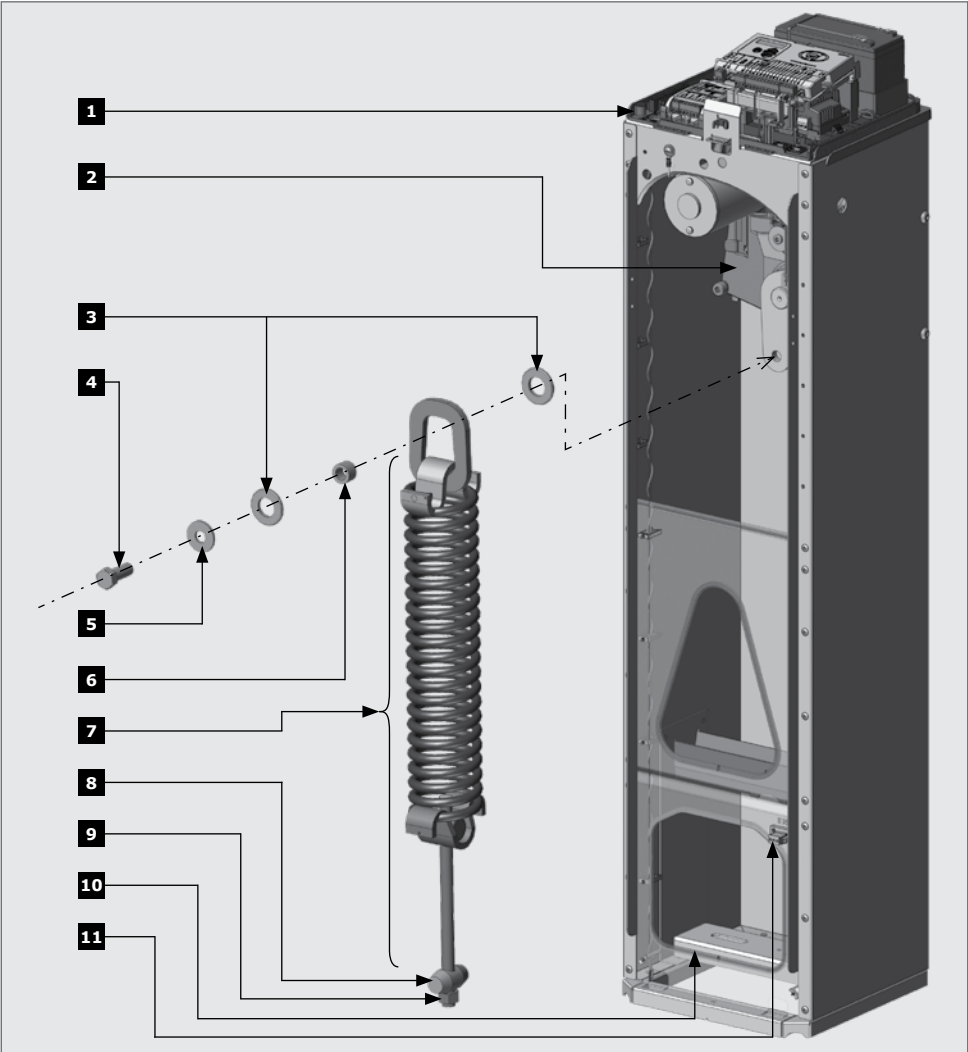

FIGURE 1. PRODUCT IDENTIFICATION - INTERNAL COMPONENTS

- | | |
|---------------------------------------|-----------------------------|
| 1. Electronics tray | 7. Counterbalance assembly |
| 2. Gearbox assembly (3m, 4,5m and 6m) | 8. Taper roller |
| 3. Spring assembly locating washer | 9. Tension-bar nut |
| 4. Spring assembly bolt | 10. Hold down bracket |
| 5. Spring-washer | 11. AC Mains terminal block |
| 6. Spring assembly bush | |

2.2. External components

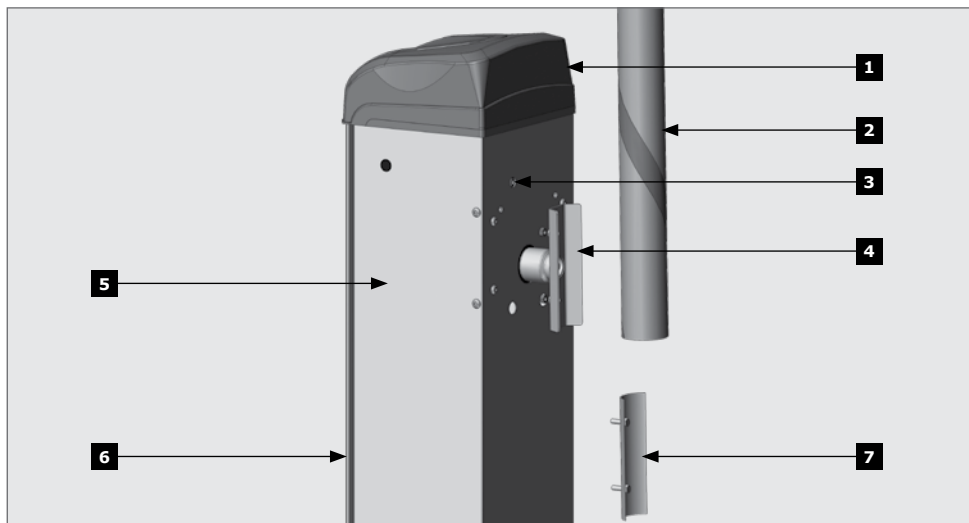

FIGURE 2. PRODUCT IDENTIFICATION - EXTERNAL COMPONENTS

- | | |
|--|-----------------------|
| 1. Barrier lid | 4. Boom pole coupler |
| 2. Boom pole (3m, 4.5m and 6m)
(not supplied) | 5. Barrier enclosure |
| 3. Manual override (6mm Allen key) | 6. Door |
| | 7. Boom pole retainer |

2.3. Electronics tray

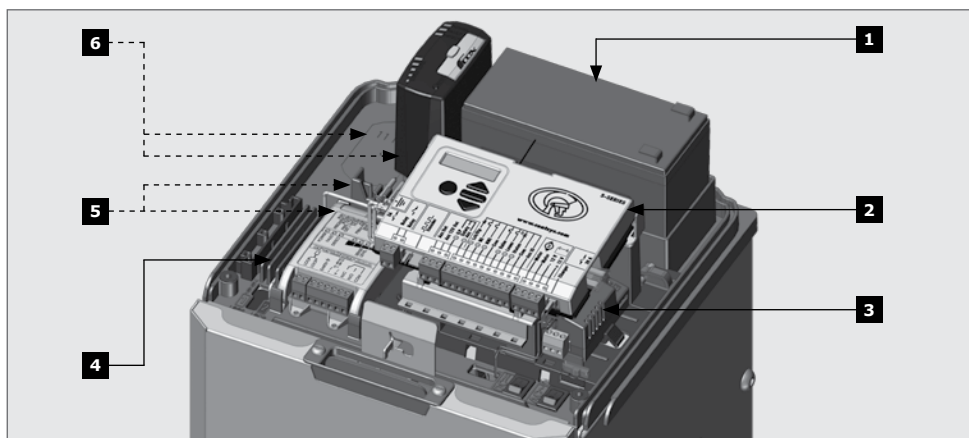

FIGURE 3. PRODUCT IDENTIFICATION - ELECTRONICS TRAY

- | | |
|-----------------------|---|
| 1. CP4 7Ah battery | 5. FLUX SA loop detector – single (optional)
FLUX SA loop detector – double (optional) |
| 2. Barrier controller | 6. FLUX 11-Pin loop detector – single (optional)
FLUX 11-Pin loop detector – double (optional) |
| 3. CP84 SM 2A charger | |
| 4. Wiring channels | |

2.4. Hardware unpacking

When unpacking the **SECTOR II**, necessary hardware can be found attached to the enclosure. The hardware is as follows:

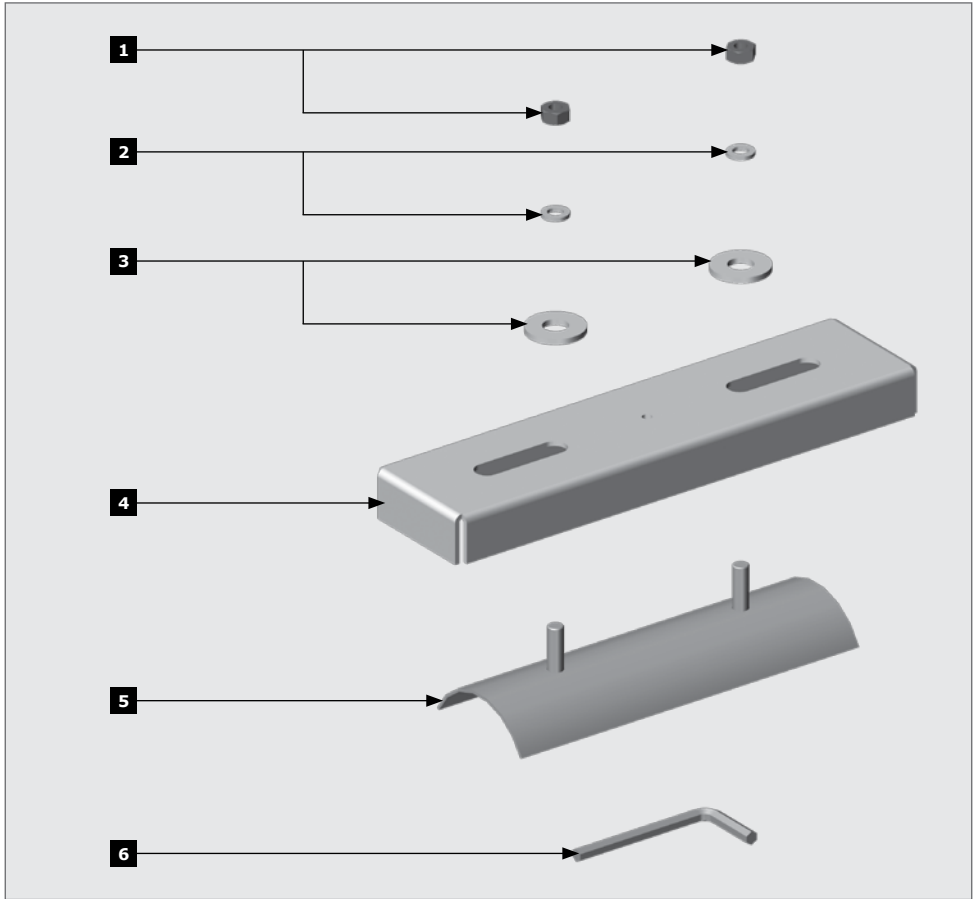

FIGURE 4. PRODUCT IDENTIFICATION - HARDWARE

- | | |
|---|---|
| <ul style="list-style-type: none"> 1. M8 Nuts
(for boom pole retainer) 2. M8 Spring Washers
(for boom pole retainer) 3. M12 Heavy duty washers
(for the Hold Down Bracket) | <ul style="list-style-type: none"> 4. Hold down bracket 5. Boom pole retainer 6. 6mm Allen key (for manual override) |
|---|---|

3. Physical installation

3.1. Preparation of the Cabinet Plinth

It is assumed that all details discussed in the document “**SECTOR II** pre-installation buyers' guide” are complete and physical installation of the system onsite is about to start.

If Section 5 of the Pre-installation Buyers' guide has not been followed, for convenience we have repeated what is requires to prepare the plinth before mounting the cabinet.

 Install an earth-spike and hold down studs (if not using rawl bolts), as shown in Figure 5 and Figure 6 before casting the plinth.

Step 6

Using medium strength concrete (25Mpa), cast the plinth with dimensions as shown in Figure 5 and Figure 6. Allow to dry.

 Ensure that 30mm of conduit protrudes above the concrete, and that the mains wires will emerge within the cabinet at least 400mm in length.

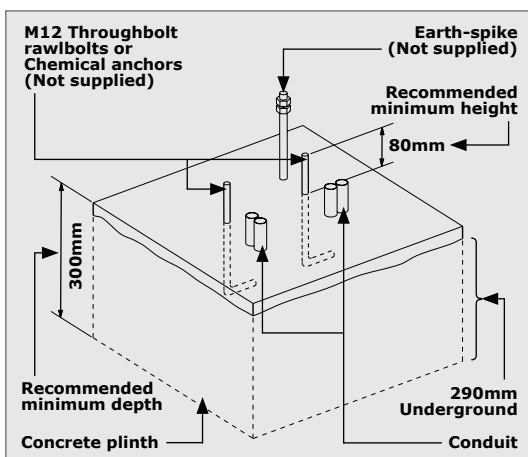



FIGURE 5. PLINTH DIMENSIONS

 Should a 33Ah battery need to be installed, the studs need to be cut to length subsequent to the **SECTOR II** being secured to the plinth.

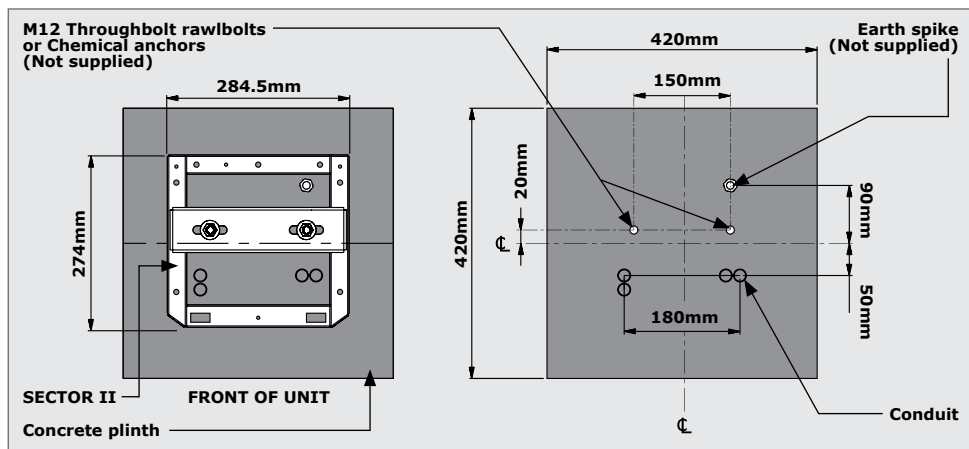

FIGURE 6

3.2. Mount the cabinet

Step 1

Remove the lid **before** removing the door.



The lid is not attached to the barrier enclosure. Hold the lid securely while pivoting it up, and removing the lid.

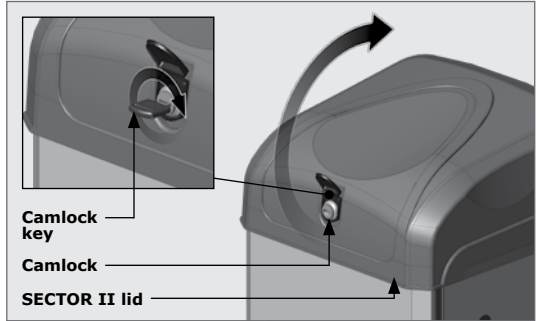

FIGURE 7



The Controller, Battery, Charger Unit, and Loop Detectors are all accessible once the lid of the **SECTOR II** has been removed.

Step 2

Pull the door release to open the door (1). The door is then removed by lifting it up and away (2).

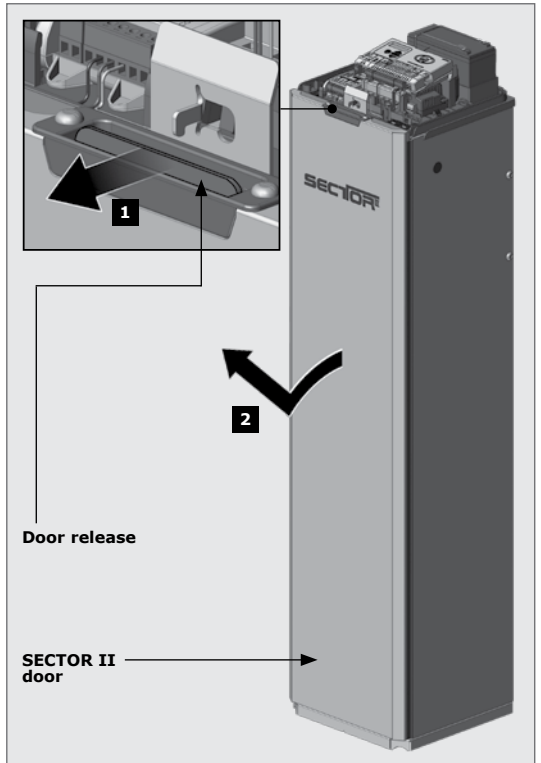

FIGURE 8

Step 3

Position the unit on the pre-installed plinth.

Step 4

Ensure that the unit is level and that the conduit and cables have suitable clearance from moving parts.

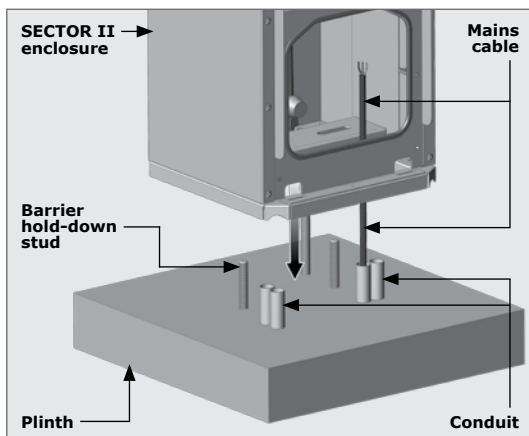

FIGURE 9

Step 5

Ensure the hold-down bracket is the right way up before securing it in position (Figure 10).

Bolt the hold-down bracket in position to clamp the barrier onto the plinth (Figure 11).

If there is a need to install the **SECTOR II** barrier in the left-hand configuration and it has not been pre-ordered, keep the barrier bolted in place. Refer to Appendix 2 - **Changing a unit to a left-hand configuration**

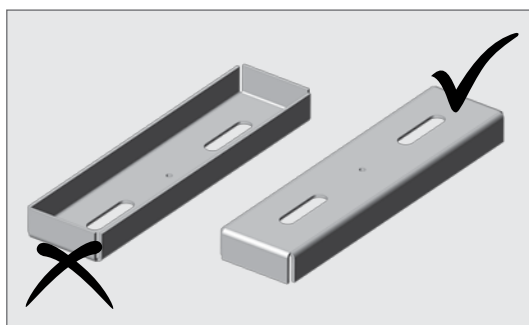

FIGURE 10

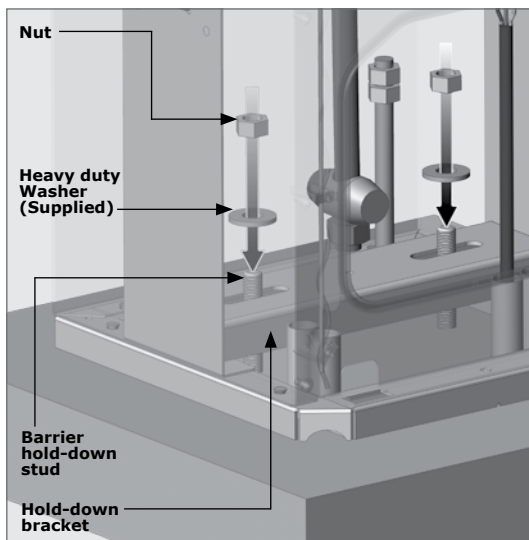

FIGURE 11

3.3. Fitting and levelling the boom pole

3.3.1. Fitting the pole

Step 1

Carefully remove the end cap from one end of the boom pole.

Step 2

Use the retainer assembly to mark a line along the pole.

Step 3

From the edge of the pole, mark and centre punch the hole positions at 65mm and 175mm (Figure 12).

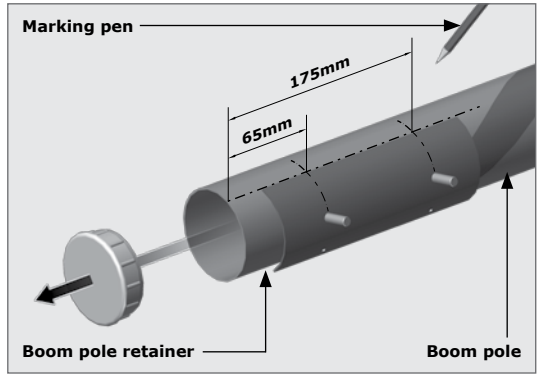

FIGURE 12

Step 4

Drill two 8.5mm holes.



Holes must be drilled through only one wall of the boom pole.

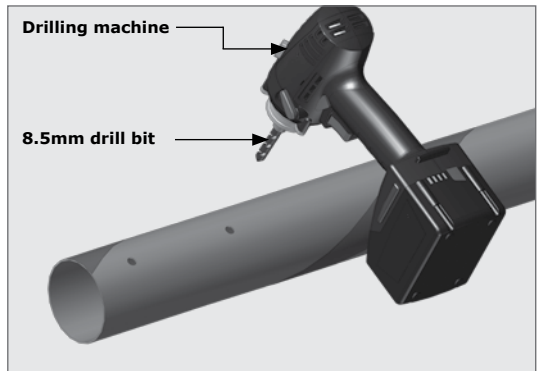

FIGURE 13

Step 5

Insert the boom pole retainer and locate the threaded studs in the drilled holes.

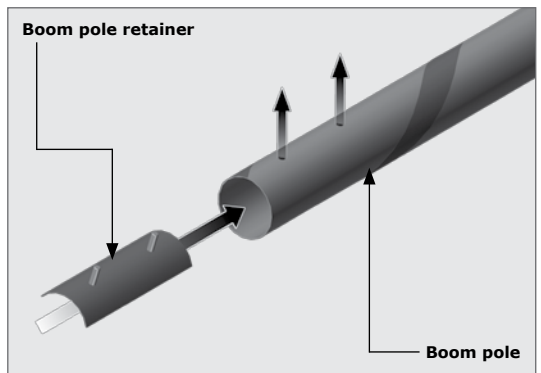

FIGURE 14

Step 6

Fasten the boom pole as shown and replace the end cap (Figure 15).

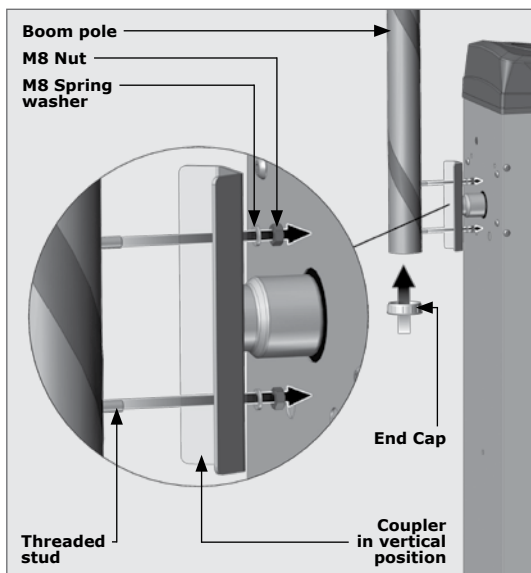

FIGURE 15

3.3.2. Leveling the boom pole



Mechanical crushing may occur

Step 1

Using the manual override, move the boom pole to the lowered position.

Step 2

If the pole is not horizontal, loosen both lock nuts on the adjustment link using 2x 17mm spanners (Figure 16).

Step 3

Adjust the adjustment link to achieve a level boom. Use a spirit level on the boom pole.

Step 4

Tighten the lock nuts using 2x 17mm spanners.

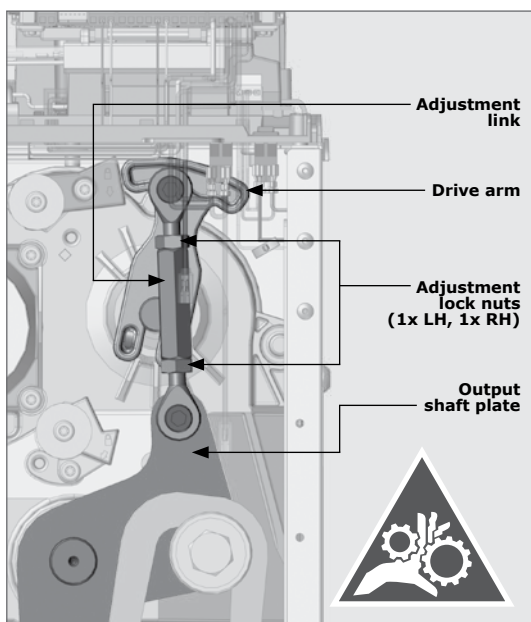

FIGURE 16



Figure 16 shows a right-hand configuration. Although the left-hand configuration looks different, the levelling procedure remains the same.

3.3.3. Coarse adjustment of the spring tension

The spring tension is adjusted at the factory. Should the spring tension need to be adjusted, follow the steps below.

Step 5

Manually override the boom pole so that it rests under the tension of the spring.

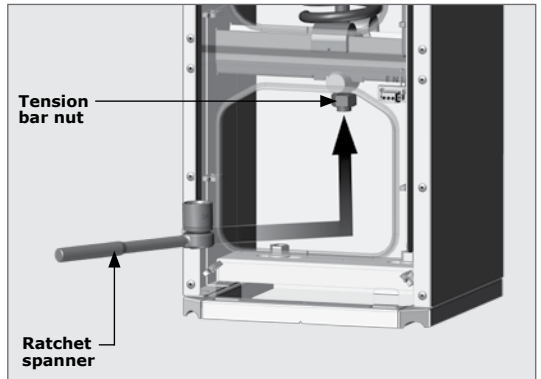

FIGURE 17

Step 6

Use a 24mm socket (4.5m and 6m boom) or a 17mm socket (3m boom) to adjust the spring so that the boom pole rests at an angle of approximately 45° . The optimal position will be determined by the electronics when the unit is set up.

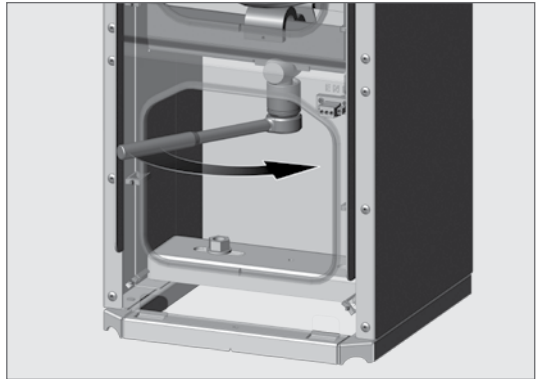

FIGURE 18

4. Onsite electrical wiring



Before commencing with wiring, ensure that all power to the SECTOR II is OFF.

4.1. AC and DC power isolation

Step 1

Switch off both the AC and DC isolators (Figure 19)

Step 2

Install and connect the 12V, 7.5Ah battery.

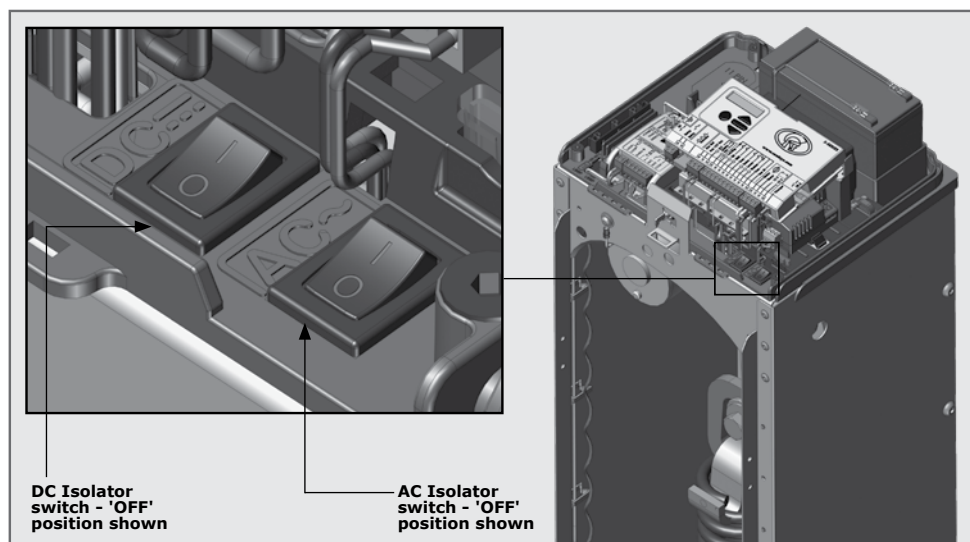

FIGURE 19

Lightning Protection

The **S-SERIES** electronic controller utilises the same proven surge protection philosophy that is used in all products from Centurion Systems (Pty) Ltd. While this does not guarantee that the unit will not be damaged in the event of a lightning strike or power surge, it greatly reduces the likelihood of such damage occurring. The earth return for the surge protection is provided via the mains power supply earth.



In order to ensure that the surge protection is effective, it is essential that the unit is properly earthed.

4.2. Earthing the unit

Connect the earth spike (Figure 20) to the designated earth point (Figure 21) using 5mm² copper-weave conductor and the self-tapping screw provided.

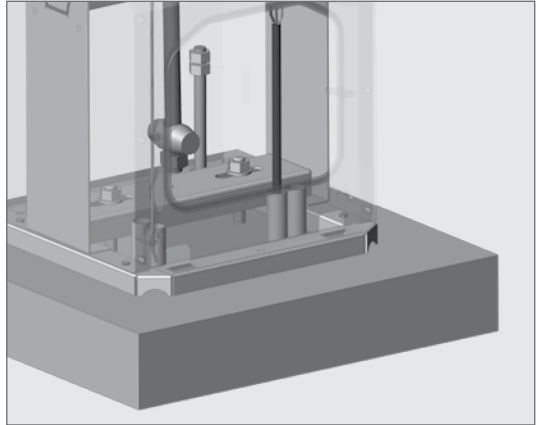

FIGURE 20

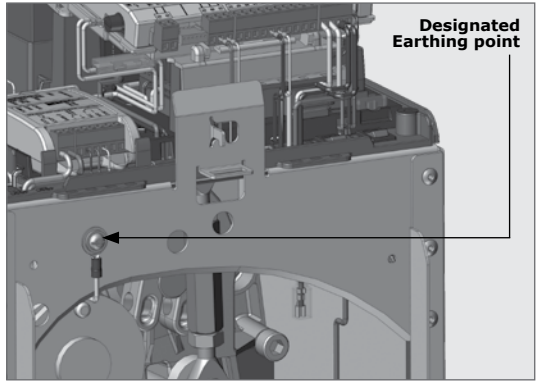

FIGURE 21

4.3. Wiring AC power to the SECTOR II traffic barrier

Route and connect the 220V AC Mains cable (Figure 22).

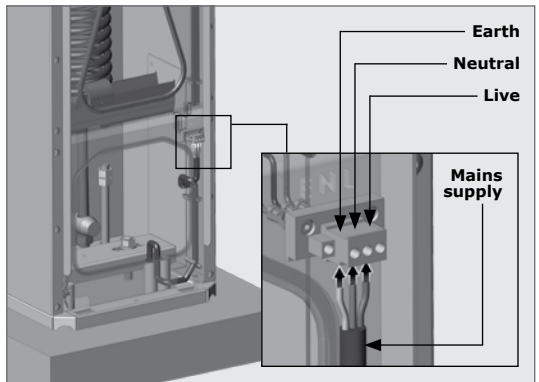

FIGURE 22

4.4. Installing loop detectors

The **SECTOR II** can use various types of loop detector.

Centurion Systems (Pty) Ltd recommends using the FLUX SA (standalone) loop detector, as the unit is easily clipped into place and wired.

Loop detector variations:

- Single FLUX SA
- Dual FLUX SA
- Single FLUX 11-pin (Appendix 4)
- Dual FLUX 11-pin (Appendix 4)

4.4.1. Installing a single FLUX SA loop detector

Step 1

Clip the FLUX SA into the electronics tray.

Step 2

Wire the FLUX SA to the controller using the supplied harness as per the wiring diagram (Figure 26).

Step 3

Run the TWISTED loop wires up inside the enclosure through the wiring clips to the FLUX SA (Figure 25). Connect the twisted loop wires to the FLUX SA.

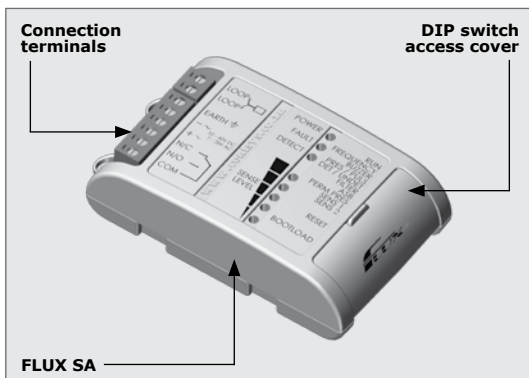

FIGURE 23

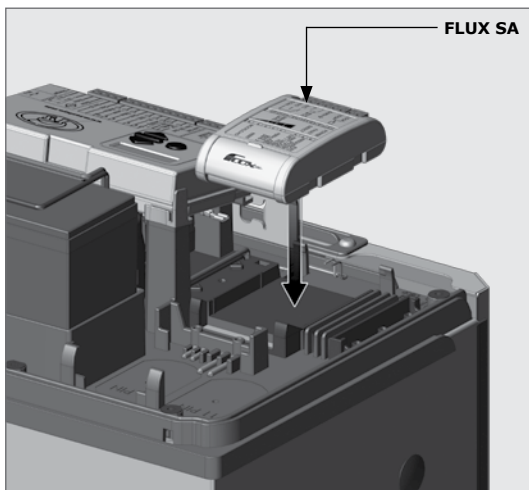

FIGURE 24

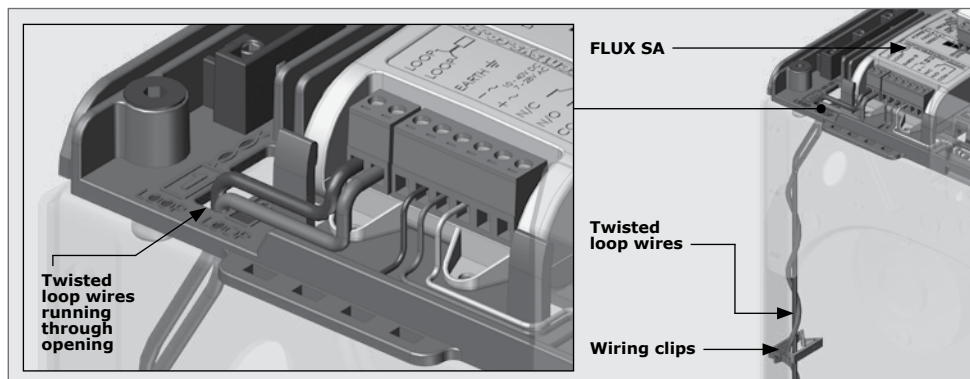

FIGURE 25

NOTE: For safety loops, Perm Presence must be turned 'ON'

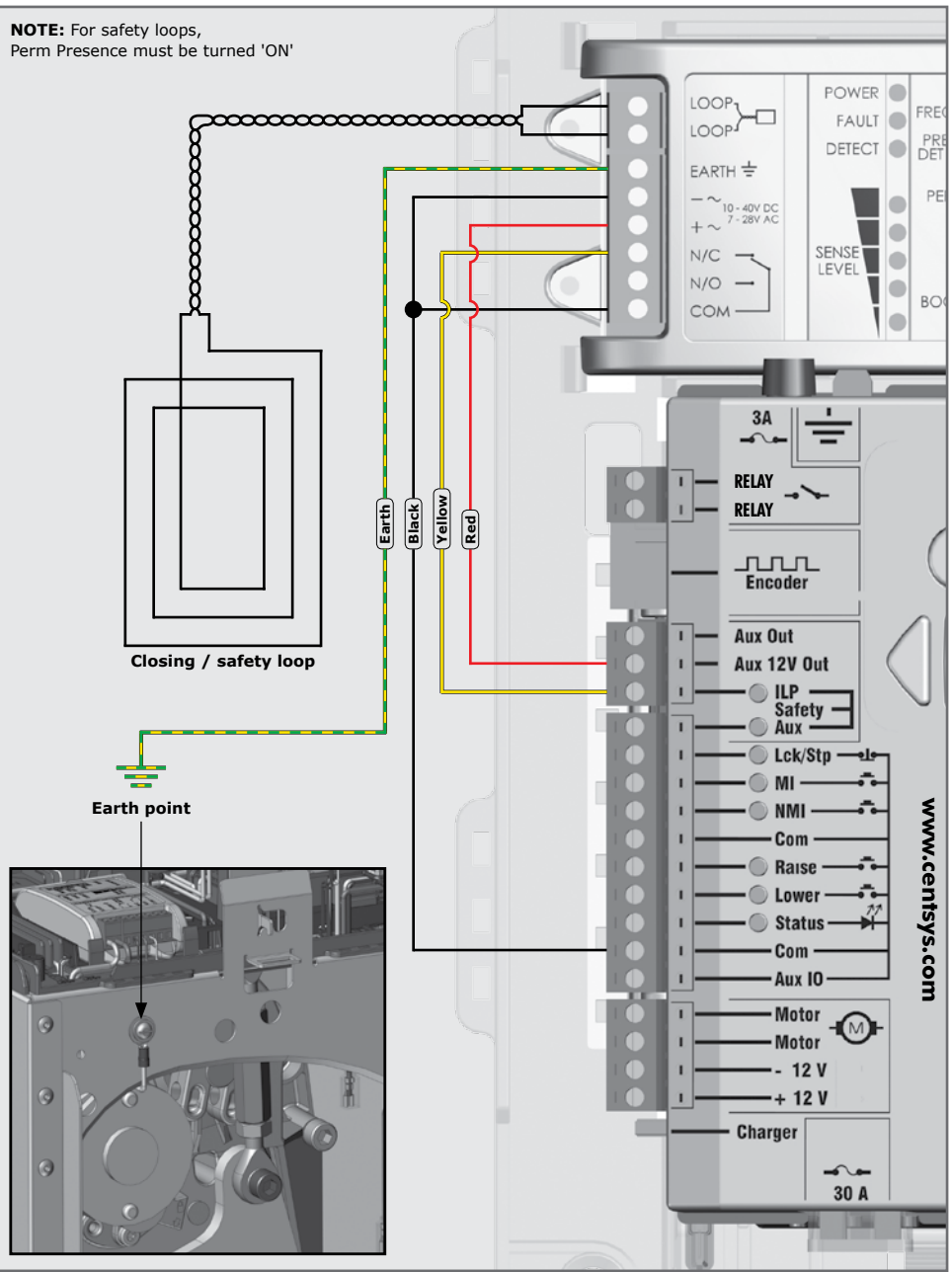

FIGURE 26. WIRING A SINGLE FLUX SA AS A CLOSING / SAFETY LOOP

DIP switch settings:

For the settings and descriptions, see the pocket-guide provided with the FLUX SA.

4.4.2. Installing dual FLUX SA loop detectors

If a free-exit loop is required in addition to the safety-loop, a second FLUX SA must be installed.

Step 1

Fit the second FLUX SA onto the electronics tray, and secure in place using the screws provided. (Figure 28).

Step 2

Wire the second FLUX SA to the controller using the supplied harness as per the wiring diagram (Figure 30).

Step 3

Run the TWISTED loop wires up inside the enclosure through the wiring clips to the second FLUX SA (Figure 29). Wire the twisted loop wires to the second FLUX SA. Take note of the wiring channel provided for the twisted loop wires.

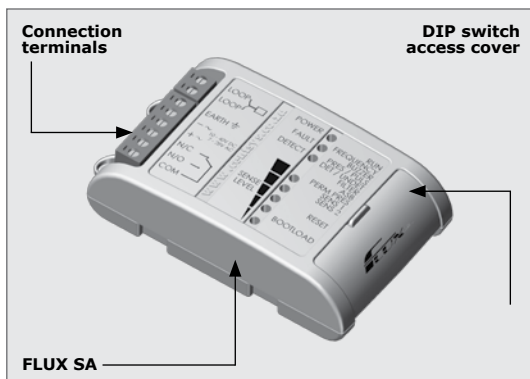

FIGURE 27

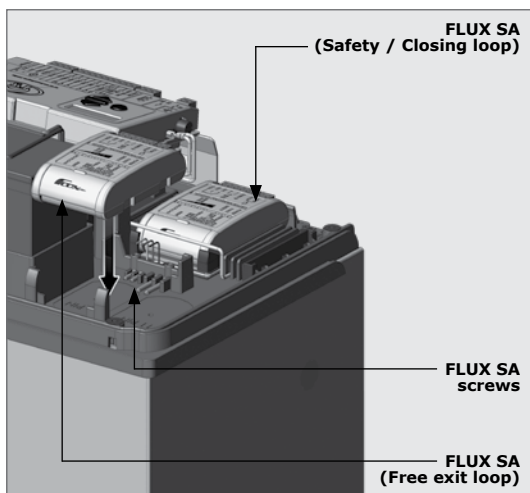

FIGURE 28

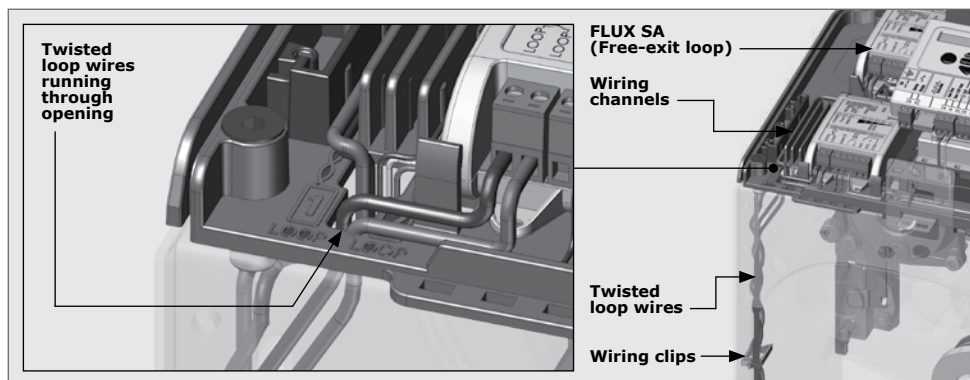

FIGURE 29

NOTE: For safety loops, Perm Presence must be turned 'ON'

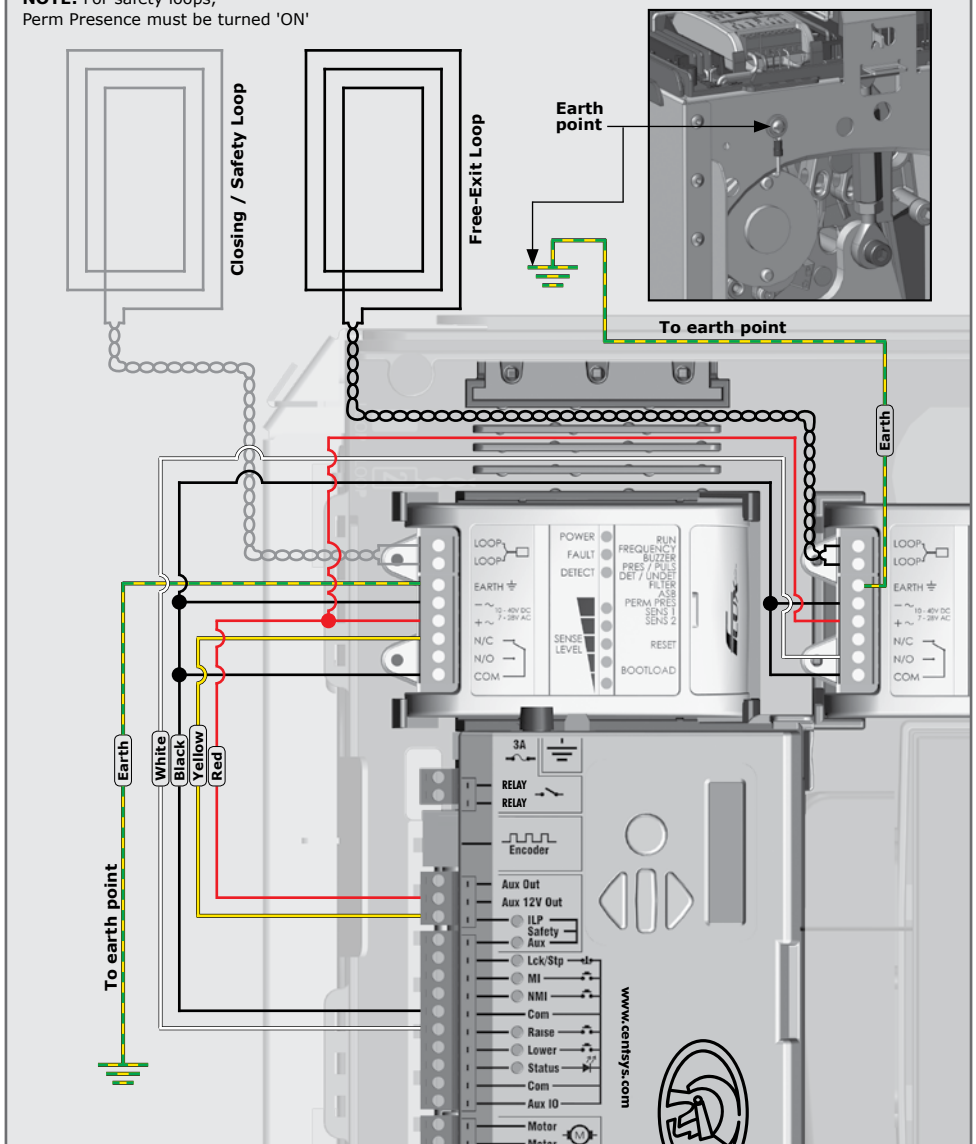

FIGURE 30. WIRING THE FLUX SA IN A DUAL LOOP CONFIGURATION



If FLUX 11-pin loop detectors are preferred, refer to Appendix 4 (Section 10.4) for the installation instructions and wiring.

5. Basic controller setup

5.1. Powering up the SECTOR II

The unit is now ready to be set up and programmed according to the installation requirements of the site. Switch the isolator 'ON' (to provide power to the battery charger) and connect the 12V battery wires to the battery. The battery should be installed in its holder and wired to the controller using the battery leads supplied.

5.2. Programming the controller

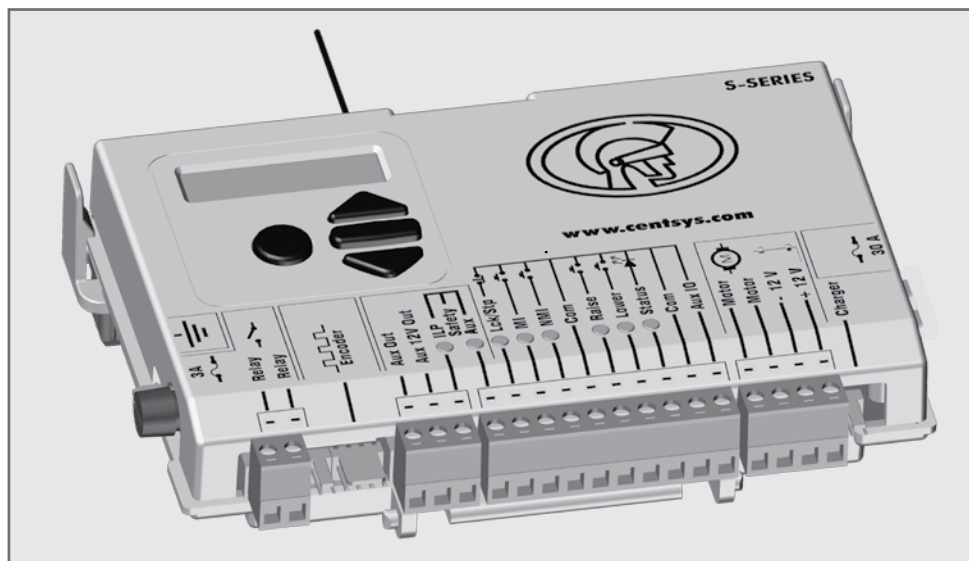

FIGURE 31. S-SERIES CONTROLLER

Menu 1 - Setting up the limits

When setting up the **SECTOR II** via the LCD display, follow all the stages that are shown on the display. To start the setup do the following:

- Press and hold the oblong () enter button for two seconds to enter Setup Mode
- If powering up for the first time (ex-factory), select the required profile that will suit your specific region (ZA - for South Africa, CE - for Europe and UL325¹ - for North America/ Canada)
- With this set, the system will automatically proceed to the Limit Setup menu. Follow the on-screen instructions to complete the setup procedure
- If powering up at any point after this, press and hold the oblong () enter button for two seconds to enter the programming menu again



1. The Regional Operating Profile is compliant with UL325 regulatory standard, but the barrier is not certified.

Adjusting the spring tension

The controller will assist with adjusting the spring tension.

If the boom pole is badly out of balance, the controller will emit a beep each time the **SECTOR II** is operated (Figure 32 error message). The spring must be tensioned as described below. If the spring is within an acceptable tension window (Figure 33 message), adjustment is not necessarily required. However, the number in the block should ideally be zero.

Step 1

Place the **SECTOR II** into Simplex Mode (Menu 4).

Step 2

Access the spring adjustment menu by pushing the down arrow once when the unit is out of programming mode.



Only tension the spring when the boom pole is in the raised position.

If the pole is not balanced, refer to Figures 32 and 33.



To refresh the display, perform two complete cycles using the round button. This will update the number in the middle. Once it shows a 0 (zero), the spring is balanced. **Keep your hands clear of any mechanical parts whilst operating the barrier!**

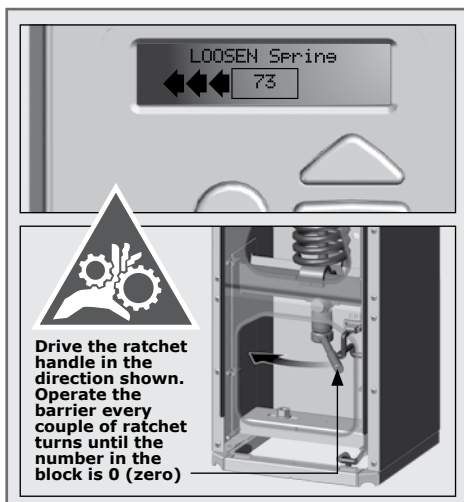

FIGURE 32. UNBALANCED SPRING

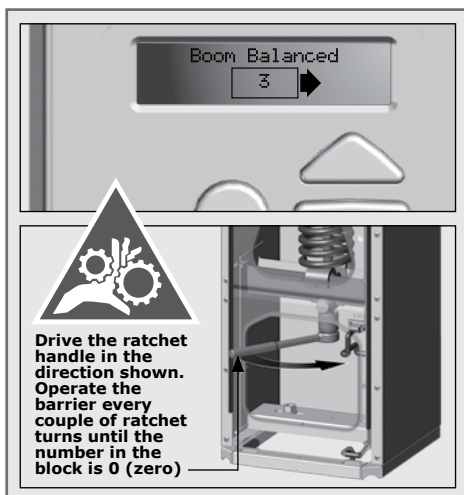

FIGURE 33. SPRING WITHIN BALANCE WINDOW

Menu 2 - Safety Collision Force

The collision force can be set independently for raising or lowering operation, from minimum to maximum¹, in five incremental steps. A sixth step will disable collision sensing entirely, allowing maximum force to be achieved. The motor will only shut down when its stall point is reached in this case. Stall-level is adjustable; refer to Torque-Limit under Menu 5.

The maximum force-setting should only be used if additional safety measures are taken; for example, inductive loops, etc. The response of the system to a collision will vary, depending on the operating standard (e.g. CE, UL325) selected.

2.1 Collision force

Collision force setting satisfies UL325, but the **SECTOR II** barrier itself is not certified.

2.2 Collision count

The number of sequential collisions that the system will allow, before shutting down the controller, if the boom pole does not reach the lowered position.

The counter resets each time the boom pole reaches its lowered position. A valid trigger input will clear the shutdown.

2.3 Alarm output

An alarm is activated if the multiple-collision-shutdown is triggered. This menu item configures the different alarm outputs.

2.4 LCK input as ESTOP

Allows the LCK (Holiday Lockout) input to be configured as an emergency-stop input.

1. Maximum does not imply maximum sensitivity to collision; it implies that the **SECTOR II** barrier will drive with maximum force.

Menu 3 - Autolower

Refer to the advanced controller setup for more information (Section 7).

Menu 4 - Modes of Operation

For a detailed explanation of the Modes of Operation provided by the **SECTOR II** traffic barrier, please refer to the appropriate section in the Buyer's Guide.

Menu 5 - Run Profile

Refer to the advanced controller setup for more information (Section 7)

Menu 6 - Setting up the Loop Detector(s) and testing

To set up the loop detector options, hold the middle oblong button for 2 seconds. Scroll to Menu 6: Loop Detectors.

6.1 ILAC (Inductive Loop Autoclose) Control

Causes the boom to Autolower as soon as the closing-inductive loop is cleared, i.e. the vehicle moves off the loop.

6.2 ILD Input to AUX Out

This is used when a user wants to know the status of the inductive-loop detector i.e. vehicle present, or not present.

6.3 Roll back time

The boom pole will raise if a vehicle is detected within this period. Thereafter the boom will not raise.

6.4 FRX (Free-exit) loop direction

Allows a single access point with bi-directional traffic to make use of a free-exit loop. Due consideration must be given to closing and free-exit loop positioning.

6.5 Inductive loop alarms

While the boom pole is lowered, this feature allows the following alarms:

- **Presence alarm** - Activates an alarm if the closing-loop has been continuously activated for a predefined time. The alarm will remain activated while the closing-loop is activated
- **Presence time** - The time for which the closing-loop must be continuously activated before the alarm is activated
- **Break-in alarm** - Activates an alarm if the closing-loop is activated while the boom is lowered. The alarm remains active while the closing-loop is activated, and for a period of 30 seconds thereafter. This time is fixed
- **Alarm output** - This menu item configures the different alarm outputs

Once the required changes are made, exit the menu by pressing the round button.

Menu 7 to Menu 14

Refer to the advanced controller setup for more information (Section 7)

6. Installation handover

Once the installation has been successfully completed and tested, it is important to explain the operation and safety requirements of the system to the end-user.

NEVER ASSUME THE USER KNOWS HOW TO SAFELY OPERATE AN AUTOMATED BARRIER!

Even if the user has used one before, it does not mean he knows how to SAFELY operate it. Make sure that the user fully understands the following safety requirements before finally handing over the site.

The following needs to be understood by the user:

- How to operate the manual release mechanism
(Show them how by demonstration)
- How the safety loops and all other safety features work
(Show them how by demonstration)
- All the features and benefits of the operator, i.e. Safety loops, etc
- **All the safety considerations associated with operating an automated barrier. The user should be able to pass this knowledge on to all other users of the automated system and must be made aware of this responsibility**

- Do not activate the barrier unless you can see it and can determine that its area of travel is clear of people, pets, or other obstructions
- **NO ONE MAY GO UNDER A MOVING BARRIER.** Always keep people and objects away from the barrier
- **NEVER LET CHILDREN OPERATE OR PLAY WITH THE BARRIER CONTROLS,** and do not allow children or pets near the barrier area
- Be careful with moving parts and avoid close proximity to areas where fingers or hands could be pinched
- Secure all easily-accessed barrier operator controls in order to prevent its unauthorised use
- Keep the automated barrier system properly maintained, and ensure that all working areas are free of objects that could affect its operation and safety
- On a monthly basis, check the obstruction detection system and safety devices for correct operation
- All repair and service work to this product must be done by a suitably qualified person
- This product was designed and built strictly for the use indicated in this documentation. Any other use, not expressly indicated here, could compromise the good condition/operation of the product and/or be a source of danger!



Neither Centurion Systems (Pty) Ltd, nor its subsidiaries, accepts any liability caused by improper use of the product, or for use other than that for which the automated system was intended.

Ensure that the customer is in possession of the user guide and that you have completed the installation details in the back of the manual.

Standard installation is now complete

At this point, a simple installation of a **SECTOR II** has been completed. Should the installation require other adjustments to be made to the standard settings, these can be found from Section 7 onwards. We recommend that these menus be carefully considered and adjustments applied to the installation, if required.

7. Advanced controller setup

Setting up additional features for the SECTOR II barrier

The **SECTOR II** navigation map (Section 7.1), provides the full menu of features that can be set up on the system.

A brief explanation of each feature is provided under each menu heading. When setting up additional features, all the stages that have to be followed are clearly provided via the display. It is only necessary to note the following:

- To get into Setup Mode, press and hold the oblong () enter button for two seconds and follow the onscreen instructions
- The buttons provided on the controller for navigating the system are blank because their functions vary within each menu and are indicated on the LCD display

7.1. Menu navigation map for the S-SERIES controller



1. Setting Limits



1.1. Setup Wizard



2. Safety

- 2.1. Collision force
 - 2.1.1. Opening collision force
 - 2.1.2. Closing collision force
- 2.2. Collision count
- 2.3. Alarm output
- 2.4. LCK Input as ESTOP



3. Autolower

- 3.1. Autolower status
- 3.2. Autolower timer
- 3.3. Autolower override
- 3.4. Autolower advanced options
 - 3.4.1. Autolower fully raised
 - 3.4.2. Autolower partly raised
 - 3.4.3. Autolower partly lowered



4. Modes of Operation

- 4.1. Operating mode



5. Run Profile

- 5.1. Lock boom at endpoints
 - 5.1.1. Lock when raised
 - 5.1.2. Lock when lowered
 - 5.1.3. Holding force
- 5.2. Raise when mains fail
- 5.3. Spike interface
- 5.4. Pre-raising delay
- 5.5. Pre-lowering delay
- 5.6. Raising speed
- 5.7. Lowering speed
- 5.8. Ramp-up distance
- 5.9. Ramp-down distance
- 5.10. TRG stop distance
- 5.11. Loop stop distance
- 5.12. Crawl distance
- 5.13. Torque limit



6. Loop Detector

- 6.1. ILAC control
- 6.2. ILD input to Aux Out
- 6.3. Rollback time
- 6.4. FRX loop direction
- 6.5. Inductive loop alarms
 - 6.5.1 Presence alarm
 - 6.5.1.1. Presence alarm status
 - 6.5.1.2. Presence time function
 - 6.5.2. Break-in alarm
 - 6.5.3. Alarm output



7. Traffic Light

- 7.1. Traffic light status
- 7.2. Traffic light function output
- 7.3. Trigger level



8. Barrier Status

- 8.1. Barrier status
- 8.2. Function output
- 8.3. State configuration
 - 8.3.1. Lowered indication
 - 8.3.2. Raising indication
 - 8.3.3. Partly Raised indication
 - 8.3.4. Raised indication
 - 8.3.5. Lowering indication
 - 8.3.6. Partly lowered indication
 - 8.3.7. Unknown indication



9. TVI Output

- 9.1. TVI feature
- 9.2. TVI function output
- 9.3. Output polarity



10. Courtesy Light

- 10.1. Courtesy light status
- 10.2. Courtesy light function output
- 10.3. Light profile
- 10.4. Light timer



11. Spikes Control

- 11.1. Spikes interface
- 11.2. Spikes mode



12. ChronoGuard

12.1. Time and date

12.2. Time periods

12.2.1. Add time period

12.2.1.1. Auto function

12.2.1.2. Time-bar function

12.2.2. Delete time period

12.2.3. Edit review time period

12.3. Exclusions

12.3.1. Add exclusion

12.3.1.1. Auto function

12.3.1.2. Time-bar function

12.3.2. Delete exclusion

12.3.3. Edit review exclusion

12.4. Delete all time periods and exclusions



13. General Settings

13.1. Operating standard

13.2. Controller type

13.3. Reset options

13.3.1. Factory defaults

13.3.2. Delete all remotes

13.3.3. Delete all time periods and exclusions

13.3.4. Reset all

13.4. Diagnostic screen status

13.5. Round test button status

13.6. Backup eeprom



14. Remote controls - *Press button of valid transmitter (if menu is locked)*

14.1. Add remotes

14.2. Delete remotes

14.2.1. Delete by ID

14.2.2. Delete button

14.2.3. Delete by button

14.2.4. Delete not present

14.2.5. Delete all remotes

14.3. Edit remote button

14.4. Autolearn remotes

14.5. Tx menu locked

14.6. Onboard receiver enable / disable

The following provides additional information of each menu.

Menu 1 and Menu 2

Refer to the basic controller setup for more information (Section 5).

Menu 3 - Autolower

The **SECTOR II** can be set to Autolower the boom under many different circumstances. The following options are available;

3.1 Autolower status

If enabled, the boom pole will automatically lower after a preset Autolower time.

3.2 Autolower time

The Autolower time can be set anywhere from 1 to 240 seconds (four minutes).

3.3 Autolower override

If turned on, this menu provides a way for a user to temporarily turn off Autolower. To achieve the functionality, the user would activate and maintain the Memory Input for longer than the Autolower Override Time. Activate Memory Input to clear the override.

3.4 Autolower advanced options

Set the conditions under which the boom pole will automatically lower. More than one condition can be selected:

- **Autolower fully raised**
Automatically lower the boom if boom pole is fully raised
- **Autolower on partly raised**
Automatically lower the boom pole if it has been stopped partially raised
- **Autolower on partly lowered**
Automatically lower the boom pole if it has been stopped partially lowered

Menu 4 - Modes of Operation

Refer to the Pre-installation Buyer's Guide for more information.

Menu 5 - Run Profile

The run profile of the **SECTOR II** can also be set. This allows the overall behaviour of the traffic barrier to be fine-tuned in order to meet the user's unique requirements;

5.1 Lock boom pole at endpoints:



Fail-safe mode

In the event that electronic locking is not required and mechanical locking is preferred, refer to Section 10.3 to adjust the endstops into their locking positions.

- Lock when raised - mechanically lock boom pole in raised position. Use manual override key to override
- Lock when lowered - as per above for lowered position
- Holding force - force used to automatically hold the boom pole in the raised or lowered position if 'lock at endpoints' is not selected



The locking endstops must be set for the locking feature to be effective.

5.2 Raise when mains fail

If enabled, the boom pole will raise in event of a mains power failure. Boom pole will remain raised until mains power is restored.

5.3 Spike interface

If enabled, this facility allows the **S-SERIES** controller to communicate with co-installed CLAWS roadway spikes.

5.4 Pre-raising delay

Allows a delay between a valid trigger signal and the boom pole raising. Can activate a warning light during delay if the TVI is not selected. (Refer to pre-flash modes of the courtesy light feature, for more details.)

5.5 Pre-lowering delay

Identical to above, except for boom pole lowering.

5.6 Raising speed

Sets the maximum raising speed in degrees per second.

5.7 Lowering speed

Sets the maximum lowering speed in degrees per second.

5.8 Ramp-up distance

Sets the ramp-up distance in degrees.

5.9 Ramp-down distance

Sets the ramp-down distance in degrees of travel of the boom pole when stopping.

5.10 TRG stop distance

Sets the angle over which a moving boom pole will stop after a trigger signal is received.

5.11 Loop stop distance

Sets the angle over which a moving boom pole will stop after a safety input is triggered.

5.12 Crawl distance

Sets the final crawl distance in degrees of travel of the boom pole when reaching an endpoint.

5.13 Torque limit

Sets the maximum torque delivered by the motor. This is useful in cases where limited push force is required.

Menu 6 - Loop Detector

Refer to the basic controller setup for more information (Section 5).

Menu 7 - Traffic Light

The **S-SERIES** controller provides the facility to control an externally-mounted traffic light (The traffic light is an ancillary product and may be purchased from Centurion Systems (Pty) Ltd). The purpose of the traffic light is to signal to road users that it is safe to travel across the barrier threshold.

7.1 Traffic Light Status

The traffic light feature is enabled or disabled in this menu. By default, the feature is enabled in all current operating profiles (ZA, CE, UL325)¹. In the event that a traffic light feature is not needed based on specific site requirements, the feature may be turned OFF via this menu. If the feature is turned OFF, the physical output associated with the feature (configured in Menu 7.2) will be driven to, and remain in, an inactive state.

7.2 Traffic Light Function Output

The logic signalling of the feature is routed to a physical controller output based on the setting specified in this menu. There are four physical controller outputs that are available for output routing. The outputs are listed in the table below, along with the relevant electrical characteristics of the respective outputs:

Output setting on controller	Output Description	Output Type	Electrical Switch Characteristics
RLY	Relay	Dry Contact	24V DC/250V AC, 2A contact
XIO	Aux IO	Open Drain	Open Drain – 3A sink current, with a 3V floating terminal Voltage.
AUX	Aux Out	Open Drain	Open Drain – 3A sink current
LED	Status LED	Open Collector	Open Collector 5V – 50mA Source

TABLE 2

7.3 Trigger Level

Specifies the arc angle that triggers the transition of the relevant output signal from an inactive state to an active state. From 0 degrees up to but excluding the specified angle², the output is always inactive (normally-open, or floating depending on the configured output used). From the specified angle through to 90 degrees inclusively, the output is active (normally-closed, or active low depending on the configured output used). The Trigger Level is specified as an arc angle, measured in degrees. The angle is measured with respect to the horizontal (0 degrees), increasing in the opening or raising direction of the barrier.

1. Please note that it should not be taken for granted that the traffic light feature will always be enabled by default. Future statutory requirements may dictate that this feature is not enabled by default in one or other of the operating profiles.
2. For the purposes of clarity, in the event that the Trigger Level is set to 0 degrees, the output will transition to the active state as soon as the barrier transitions to the RAISING state. In other words, the traffic light will go green as soon as a raising command is executed by the **SECTOR II**.

Menu 8 - Barrier Status

The **S-SERIES** controller provides a feature to indicate a barrier operating state (e.g. Lowered, Raising, Raised, etc), or set of states, to an external device. The purpose of this is to signal the operating condition of the **SECTOR II** barrier to some external piece of equipment (e.g. Interlocked access control equipment such as another barrier or a gate operator, programmable logic controllers, alarm systems, etc).

8.1 Barrier Status

The Barrier Status Indication feature can be turned ON or OFF, independent of any other settings associated with the feature. If the feature is turned OFF, the physical output associated with the feature (configured in Menu 8.2) will be driven to, and remain in, an inactive state.

8.2 Barrier Status Function Output

The logic signalling of the feature is routed to a physical controller output based on the setting specified in this menu. There are four physical controller outputs that are available for output routing as shown below:

Output setting on controller	Output Description	Output Type	Electrical Switch Characteristics
RLY	Relay	Dry Contact	24V DC/250V AC, 2A contact
XIO	Aux IO	Open Drain	Open Drain – 3A sink current, with a 3V floating terminal Voltage.
AUX	Aux Out	Open Drain	Open Drain – 3A sink current
LED	Status LED	Open Collector	Open Collector 5V – 50mA Source

TABLE 3

8.3 State Configuration

Each of the seven operating states can be independently configured to drive the output active (ON) or inactive (OFF) according to the table below. The RAISING and LOWERING states offer additional configuration options, allowing the output to transition to an active or inactive state if the barrier is above or below a particular arc angle.

- In the RAISING state, the output will start in the inactive state, and transition to the active state if the barrier is at or above the specified arc angle
- In the LOWERING state, the output will start in the active state, and transition to the inactive state if the barrier is at or below the specified arc angle

Barrier State	Option		
Barrier lowered	OFF	ON	
Barrier raising	OFF	ON ¹	5°, 10°, 15°, 20°,... 80°, 85° ²
Barrier partly-raised	OFF	ON	
Barrier raised	OFF	ON	
Barrier lowering	OFF	ON ³	5°, 10°, 15°, 20°,... 80°, 85°
Barrier partly-lowered	OFF	ON	
Unknown indication	OFF	ON	

TABLE 4

1. The output will transition to the active state as soon as the barrier transitions to the RAISING state.
2. The arc angle is specified in degrees. The angle is measured with respect to the horizontal (0°), increasing in the opening or raising direction of the barrier.
3. The output will transition to the active state as soon as the barrier transitions to the LOWERING state.

Menu 9 - Ticket Vendor Interlock (TVI) Output

The Ticket Vendor Interlock feature provides an interlocking mechanism between a ticket vending machine, and the **SECTOR II** barrier.

In the interlock configuration, the ticket vending equipment activates the barrier when a ticket for access is validly issued. The barrier now needs to interlock (prevent) further tickets from being issued while the barrier is raised. The interlock expires when the barrier reaches the closed position again.

9.1 TVI Output Status

The TVI Output feature can be turned ON or OFF, independent of any other settings associated with the feature. The TVI Output feature is turned off by default. If the feature is turned OFF, the physical output associated with the feature (configured in 9.2) will be driven to, and remain in, an inactive state.

9.2 TVI Function Output

The NMI input will react differently depending on whether the TVI feature is enabled or not. The NMI input will react as follows;



If the TVI feature is Enabled, the barrier will only activate when the NMI input is released, that is, when the NMI input is connected to COM via a switching circuit, the barrier will only activate when the switching circuit opens.

If the TVI feature is Disabled, the barrier will activate when the NMI input is activated, that is, when the NMI input is connected to COM via a switching circuit, the barrier will activate as the switching circuit closes.

The outputs are listed in the table below, along with the relevant electrical characteristics of the respective outputs:

Output setting on controller	Output Description	Output Type	Electrical Switch Characteristics
RLY	Relay	Dry Contact	24V DC/250V AC, 2A contact
XIO	Aux IO	Open Drain	Open Drain – 3A sink current, with a 3V floating terminal Voltage.
AUX	Aux Out	Open Drain	Open Drain – 3A sink current
LED	Status LED	Open Collector	Open Collector 5V – 50mA Source

TABLE 5

9.3 TVI Output Polarity

The **SECTOR II** can be used with various ticket vending equipment. To accommodate this flexibility, the polarity of the interlock signal can be reversed in situations where the ticket vending equipment is not directly compatible in the standard configuration of the interlock signal.

N/C	Physical output is normally-closed or active low (depending on output specified) when the interlock is active
N/O	Physical output is normally-open or floating (depending on output specified) when the interlock is active.

TABLE 6

Menu 10 - Courtesy Light

The courtesy light circuit on the controller is a convenient way to electronically coordinate the behaviour of pillar lights, or security lights, with the movement of the traffic barrier. Typically the courtesy lights will switch on when the barrier is triggered, and stay on for a period of time after the barrier lowers to illuminate the area around the barrier for the sake of both security and convenience. However, the courtesy light circuit has a number of other useful profiles that can be configured to control the behaviour of the light in different situations. The general functional behaviour of each profile is highlighted in Section 10.3.

10.1 Courtesy Light Status

The courtesy light feature can be turned ON or OFF, independent of any other settings associated with the feature. The courtesy light feature is turned off by default. If the feature is turned OFF, the physical output associated with the feature (configured in Menu 10.2) will be driven to, and remain in, an inactive state.

10.2 Courtesy Light Function Output

The outputs are listed in the table below, along with the relevant electrical characteristics of the respective outputs:

Output setting on controller	Output Description	Output Type	Electrical Switch Characteristics
RLY	Relay	Dry Contact	24V DC/250V AC, 2A contact
XIO	Aux IO	Open Drain	Open Drain – 3A sink current, with a 3V floating terminal Voltage.
AUX	Aux Out	Open Drain	Open Drain – 3A sink current
LED	Status LED	Open Collector	Open Collector 5V – 50mA Source

TABLE 7

10.3 Courtesy Light Profile

One of four lighting profiles can be selected based on the table below:

Light Profile	Profile Description
CUR	Courtesy Light Profile
PFA	Pre-Flash A
PFB	Pre-Flash B
PFC	Pre-Flash C

TABLE 8

The profile controls the light to act as a courtesy light. Any barrier activation will switch on the light. The light stays on while the barrier moves, or during any form of pre-delay. Once the barrier is stationary, the light will remain on for the time set by the 'Courtesy Light Time' setting. After which, the light will switch off.

Pre-Flash A Profile (PFA) – The light will only switch on while the barrier is moving. The light will switch off or remain off in all stationary states, even those states that pre-empt movement (pre-open delay, pre-close delay)

Pre-Flash B Profile (PFB) – The light will flash while the barrier is moving, and during any states that pre-empt movement (pre-open delay, pre-close delay)

Pre-Flash C Profile (PFC) – The light behaves identically to Pre-Flash B profile except it doesn't flash, it simply switches on.

10.4 Courtesy Light Timer

When the pole comes to rest after any form of barrier movement (manual movement of the barrier is discounted), the controller enters a courtesy light phase. During this period, if the courtesy light profile is enabled, the courtesy light will switch on (or remain on). At the end of the courtesy light period, the light will switch off.

The 'Courtesy Light Time' setting specifies the time period of the courtesy light phase. It can be set from 4 seconds to 9h59m59s in 1 second increments.

SECTOR II Installation flow diagram pull-out



These two pages pull out and can be used for easy reference when installing your **SECTOR II** high-volume traffic barrier.

PULL OUT



Installation flow diagram

Pre-installation
(refer to pre-installation buyers guide)



Mount the cabinet
Section 3

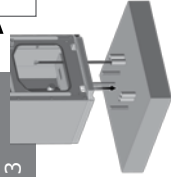

Changing orientation
Section 10.2



Fit the pole
Section 3.2

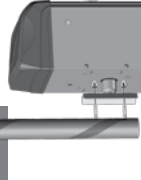

Earth and mains
Section 4.1



AC and DC isolators
Section 4.3



Install 11-pin loop detector(s)
Section 10.4



Install FLUX SA loop detector(s)
Section 4.4

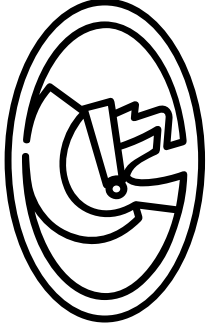

Key Chart

1	Installation mainstream
2	Sub installations
3	Optional

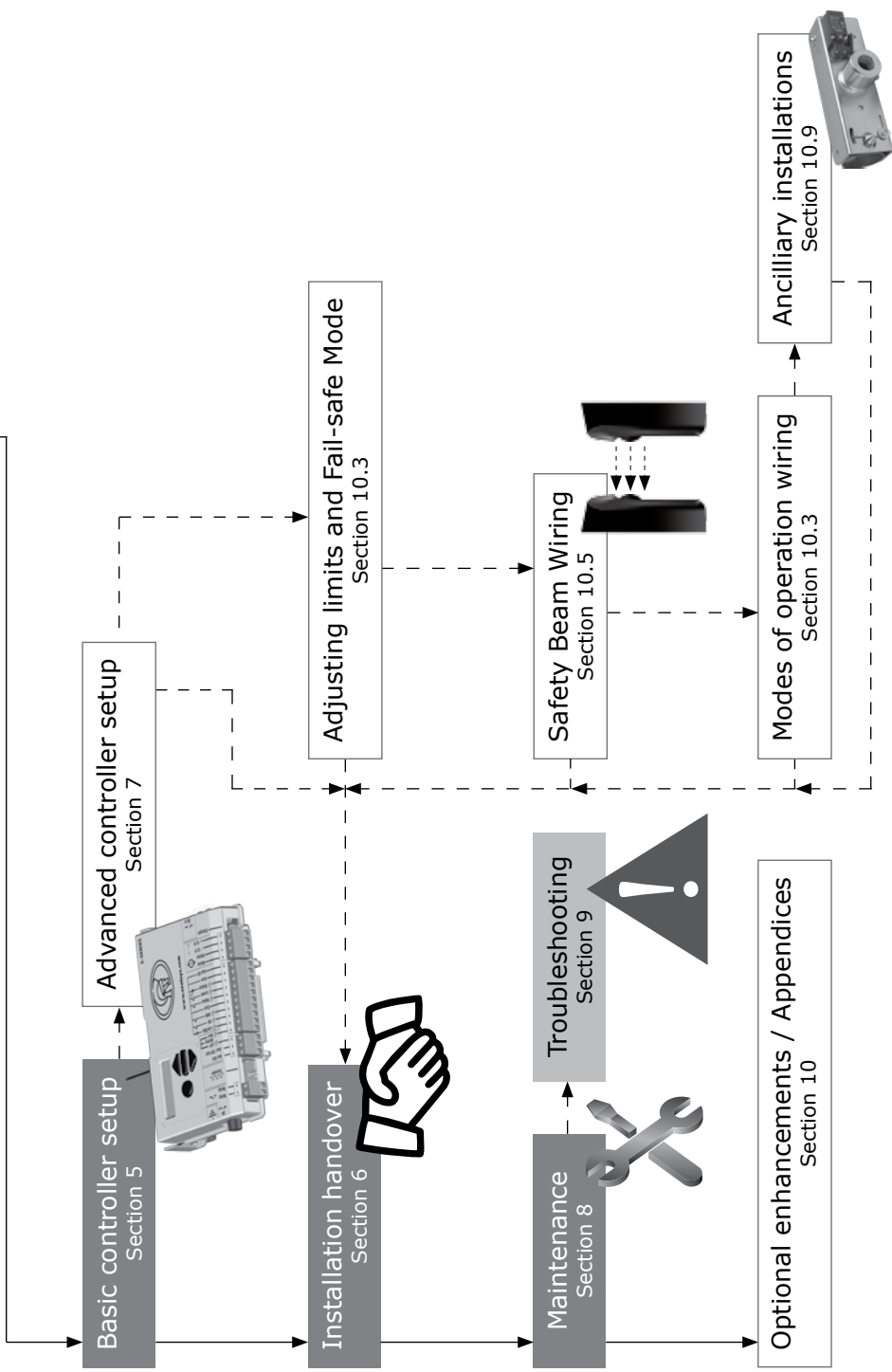

PULL OUT

SECTOR II Installation flow diagram pull-out



These two pages pull out and can be used for easy reference when installing your **SECTOR II** high-volume traffic barrier.



**FLOW CHART
INSIDE**

PULL OUT

SECTOR II INSTALLATION FLOW DIAGRAM PULL-OUT

PULL OUT

Menu 11 - Spikes Control

This menu determines how the **S-SERIES** controller interacts with the CLAWS Spikes modules. Spikes Control will interface / control Standalone or Direct Drive Spikes.

11.1 Spikes Interface

The spikes interface enables the electrical communications interface and functional barrier behaviour that allows the S-Series Controller to interface with Spikes hardware. CENTURION offers two CLAWS units that are compatible with the **SECTOR II** barrier. Refer to the CLAWS literature for further information on this product range.

11.2 Spikes Mode

The Spikes Mode setting configures the S-Series Controller to control the specific operational behaviour of the spikes and the barrier in combination. There are three Modes of Operation:

SAF - Safe Mode: This mode is only applicable to an Independent Drive system. In this mode, the barrier will only raise when the S-Series Controller has confirmed that the spikes have reached their fully lowered position. When the S-Series Controller is commanded to lower the barrier, the barrier must reach the fully lowered position, before the raise signal is issued to the CLAWS Controller.

SEC - Secure Mode: This mode is only applicable to an Independent Drive system. In this mode, the S-Series Controller will raise the barrier at the same time that the lower signal is issued to the CLAWS Controller (causing the spikes to start to lower). Similarly, the S-Series Controller will lower the barrier at the same time raise signal is issued to the CLAWS Controller (causing the spikes to start to raise).

DIR - Direct Drive Mode: This mode is only applicable to a Direct Drive CLAWS system. In this mode, the S-Series Controller will only turn the traffic light green when the spikes are in their fully lowered position. In any spikes orientation other than fully lowered orientation, the traffic will remain in a red state.

Menu 12 - ChronoGuard (Time-periods) A World First

12.1 Time and Date

ChronoGuard allows automatic activation or time-barring (prevented operation) of specific controller inputs, and the time-barring of specified remote control buttons used together with the onboard receiver. The Real-Time Clock and Calendar will maintain time-keeping for a minimum of one hour without any power.

12.2 Time-periods

A Time-period is defined by a start and end date and time. Up to 100 Time-periods can be defined. A Time-period can be set as a once-off event or repeated on a weekly or annual basis. The weekly repeat can be chosen to occur on every day of the week, weekdays only, weekends only, or any specific day. The minimum duration of a Time-period is one minute. Once-off time periods have the highest precedence, followed by annual and then weekly.

Auto-functions (Auto-activations)

Automatically activate any of the listed inputs/outputs during a time-period.

Inputs

- Barrier-raise
- Barrier-lower
- Barrier-disable (LCK) - also referred to as 'Holiday Lockout'
- Closing-loop (ILD)



In both cases, the relevant sensors must be installed for the system to operate safely and correctly.

Outputs

- Aux Out - this is an open-collector transistor output, switching to negative, used to drive an external relay for operating any external device
- Aux IO - this is a switching negative used to drive an external relay for operating any external device

Time-barring

Time-barring of inputs is divided into physical inputs and outputs mapped to a remote control button. The following physical inputs can be time-barred (prevented from operating) during a Time-period:

- Barrier-raise
- Barrier-lower
- Memory Input (MI)
- Non-memory Input (NMI)
- Barrier-disable (LCK)

The following physical outputs can be time-barred (prevented from operating) during a Time-period:

- TVI (configured as a relay to switch a Courtesy Light)
- The following remote control inputs can be time-barred (prevented from operating) during a Time-period:
 - Barrier-raise
 - Barrier-lower
 - Memory Input (MI)
 - Non-memory Input (NMI)
 - Barrier-disable (LCK)

The Time-barring of code-hopping transmitters is specified at the time of coding the transmitter into the system. Once an RF input is defined as time-barred, any time-barred transmitter associated with that input will be time-barred during the relevant time-period. If a physical/ RF input is time-barred, any attempt to activate it will be acknowledged by a short beep of the onboard buzzer. The input, however, will not activate.

12.3 Exclusions

Exclusions are used to prevent scheduled Time-periods from occurring at specific times (e.g. public holidays). While time-barring can be used to achieve a similar end, exclusions can also be used to exclude time-barring itself. Each exclusion consumes one Time-period. Exclusions have the highest precedence, followed by time-barring and then auto-functions.

12.4 Delete all Time-periods and exclusions

Override to delete all values.

Menu 13 - General Settings

13.1 Operating standard

Configure the controller to conform to the specific region's standard - e.g. UL325 or CE.

13.2 Controller Type

The S-Series Controller can be configured to perform as either a **S-SERIES** Controller or a CLAWS Controller. This flexibility simplifies the installer's stock holding of spare parts.



If Direct Drive CLAWS spikes are installed, this selection does not need to be performed.

The Controller Type Menu allows the user to verify what type of controller the S-Series Controller has been configured as.

- If the LCD display shows SECT, this indicates that the S-Series Controller has been configured to control the **SECTOR II** Barrier
- If the LCD display shows SPK, this indicates that the S-Series Controller has been configured to control the CLAWS spike module

The Select Controller Menu allows the user to change the function of the S-Series Controller. Two options are available; **SECTOR II** (SECT) and Spikes (SPK)

13.3 Reset options

- Factory defaults - Restore only the original factory defaults for the operating standard / profile chosen; no other settings are affected
- Delete all remotes - Delete all the remotes stored in the system; no other settings are affected
- Reset all - Clears the controller completely as per an off-the-production-line unit

Boom pole end-of-travel limits are not affected by any reset

13.4 Diagnostic screen

Allows a diagnostic screen to be displayed.

13.5 Round test button

Disables or enables the operation of the round test-button on the controller

Menu 14 - Adding remote controls into the system

Up to 500 remote control transmitter buttons can be learned into the memory. Each transmitter learned into the system is assigned a unique transmitter ID. In multi-button remotes it is possible to use one of the buttons as a 'shift-button' allowing six functions on a four-button remote. When adding transmitters, it is recommended that a record be kept of the ID number allocated by the system to each respective transmitter and the person to whom the transmitter is given. This is necessary should selective deletion be required at a later stage.

- If the remote controls menu has been 'locked' as discussed later, only by pressing a button of a transmitter learned into the system, can this menu be accessed
- It is possible to artificially increase the number of buttons of a multi-button transmitter by using a two-button combination
 - One of the buttons is used as a shift button to allow the other buttons to be used again in combination with this button. In other words, the user will press and hold the shift button, before pressing one of the other buttons to create a new button
 - The shift button cannot be used as a button on its own, it must always be used in combination with the other buttons

Benefits of the shift button system:

- Use of the shift button system allows a three-button transmitter to gain an extra button and operate four functions and likewise a four-button transmitter gains two extra buttons and can operate six functions
- Another benefit of using the shift button system is that it requires both hands to operate the two-button combination. This prevents the user from accidentally enabling sensitive functions such as Holiday Lockout on the controller
- Each transmitter learned into the system is assigned a unique transmitter ID

14.1 Add remote

Any button can be set to control the memory, non-memory, raise boom pole, lower boom pole and Holiday Lockout inputs

14.2 Delete remote

Transmitters can be deleted at any stage according to one of the following methods:

- Delete remote by ID - Where a record of the unique ID has been kept, delete transmitter according to this ID. It is not necessary to have the remote present to delete the ID
- Delete remote button - Clear operation of a button on a particular transmitter. The transmitter has to be present
- Delete remote by button - Delete a transmitter that is present
- Delete-not-present - Allows a time-period to be set in hours. Any remotes which have not been used within the time-period will be deleted
- Delete all remotes - Clear the entire memory of all remotes

14.3 Edit remote button

Move the function from one button to another. The transmitter must be present.

14.4 Autolearn

Allows a Time-period to be set, during which any specific button will be learned to a specific function when it is pressed. The function will also be activated when the button is pressed. After the Time-period has expired, Autolearn is disabled, and no further buttons will be learned.

14.5 Tx Menu locked

Lock the remote controls menu and prevent unauthorised addition of new transmitters. Once enabled, the remote controls menu can only be accessed by pressing a valid transmitter button.

14.6 Onboard receiver disable/enable

Disables/Enables onboard receiver.

8. Maintenance

Maintenance should be carried out at regular intervals.

The list below can be used as a schedule for maintenance procedures.

As a minimum, the following maintenance procedures should be performed on a basis that is consistent with the daily usage of the unit:

1. Tighten the two holding-down nuts.
2. Tighten the nuts holding the pole to the boom-coupler.
3. Check the boom pole level, and adjust if necessary using the level-adjustment-link (refer to Section 3.2).
4. Tighten the lock-nuts on the level-adjustment-link.
5. Check the spring tension, and adjust if necessary. A diagnostic screen indicating how many turns of the adjustment link is necessary, and in which direction, is provided on the controller (Refer to Section 5).

Special maintenance for Grade 316 Stainless steel barriers

Oxidation in marine and coastal areas may result in brown discolouration ('tea staining') of the barrier housing and, while this does not impact the structural integrity of the barrier adversely, it is unattractive and can be easily prevented by regularly washing the barrier-housing with a soft cloth and warm water. A mild detergent may also be used. This will remove salt and other corrosive materials from the housing and retain the attractive sheen of the stainless steel.

9. Troubleshooting

9.1. Diagnostics

The following diagnostics enable analysis of why the unit is not performing as expected.

Diagnostic LEDs

The **S-SERIES** controller has a series of diagnostic LEDs which indicate the state of the inputs. Normally-open inputs are indicated by a red LED, and normally-closed inputs by a green LED. An illuminated red LED indicates that the signal is present (e.g. barrier-raise pressed), while a non-illuminated green LED indicates that the signal is absent (i.e. IRB broken)

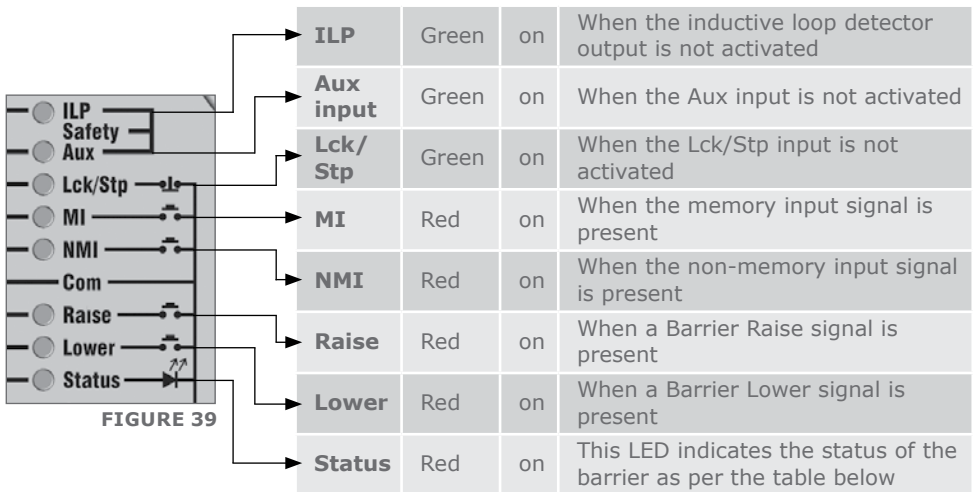

TABLE 9

SECTOR II traffic barrier status LED

Off	Barrier is lowered
On	Barrier is partially or fully raised
Continuous slow flash	Barrier is raising
Continuous fast flash	Barrier is lowering
One flash every two seconds	Pillar-Light override is activated
Two flashes every two seconds	No mains present
Three flashes every two seconds	Battery voltage is low
Four flashes every two seconds	Multiple collisions have occurred

TABLE 10

LCD display

The **S-SERIES** controller's LCD display shows valuable information regarding the status of the system.

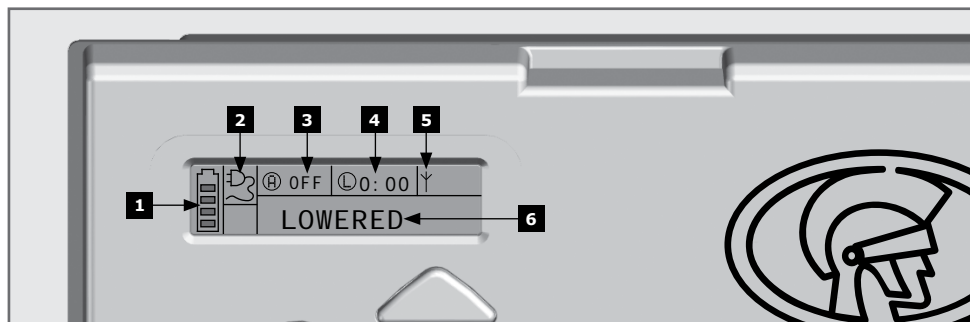

FIGURE 34. S-SERIES CONTROLLER LCD

1. Battery icon

Indicates the state of charge of the battery.

- Four solid bars = full capacity
- Two solid bars = 50% capacity
- No solid bars, with the icon flashing = battery empty

2. Mains icon

Displays the presence / absence of mains voltage:

- Plug solid = mains present and battery charging
- Plug hollow and flashing = No mains present and battery not charging

3. Autolower information

- Displays the state of the Autolower function
- Displays off if Autolower is not selected
- OVR if Autolower is overridden, and the remaining Autolower time if Autolower is active

4. Pillar Light/Ticket-Vend-Interlock (TVI) information

- Displays the remaining courtesy light time, if the courtesy-light-mode is selected
- Pre-flashing mode is displayed if pre-flash is selected
- LIT will be indicated if the pillar light has been turned on permanently
- TVI will be indicated if the TVI output has been configured

5. Onboard receiver information

- Displays the current input being activated by the onboard receiver

6. Status information

- Displays useful information regarding the status of the barrier

Buzzer feedback

A warning buzzer will sound (where applicable) as per the table below:

Inhibitor name	Priority	Number of beeps	Fault type	Boom continues to operate	User can correct error
Break-in alarm	1	Continuous tone for 30 seconds	Alarm	N/A	N/A
Presence alarm	2	Continuous tone until ILD is cleared	Alarm	N/A	N/A
Battery low	3	3 beeps periodically for 30 seconds	Power system fault	Yes ¹	Yes
Multiple collision	4	Periodic until condition is cleared by user (500/500ms)	Collision	No	Yes
Auxiliary overload	5	5 beeps periodically for 30 seconds	Hardware	No	No
Holiday Lockout	6	1 beep periodically for 30 seconds	User	No	Yes
Emergency stop	7	1 beep periodically for 30 seconds	User	No	Yes
Time-barring	8	1 beep periodically for 5 seconds	User	No	Yes
No limits set	9	3 short beeps for 5 seconds	Lost	No	Yes
Mains failure	10	2 beeps periodically for 30 seconds	Power system fault	Yes	Yes
ILD broken	11	1 beep periodically for 30 seconds	User	No	Yes
DOSS disconnected	12	5 beeps periodically for 30 seconds	Hardware	No	No
Fuse blown	13	5 beeps periodically for 30 seconds	Hardware	No	Yes
Motor disconnected	14	5 beeps periodically for 30 seconds	Hardware	No	Yes
Bridge damaged	15	5 beeps periodically for 30 seconds	Hardware	No	No
Barrier stalled	16	4 beeps periodically for 10 seconds	Collision	No	Yes

1. The boom pole will close fully and then shut down for two minutes

TABLE 11

10. Appendices

10.1. Appendix 1. SECTOR II specifications

10.1.1. Unit specifications

Depending on the site, the user will need to decide on what type of barrier is most suitable. Table 12 shows the specifications of the various units. Please note that the operator type and speed varies based on the chosen pole length.

SECTOR II traffic barrier	3 Metre ⁸	4.5 Metre ⁸	6 Metre ⁸
Input voltage	90 - 240V AC \pm 10%, 50 Hz ¹		
Motor voltage	12V DC		
Motor power supply	Battery-driven (standard capacity - 7 Ah) ²		
Battery charger	CP84SM - 1.8A @ 13.8V		
Current consumption (Mains)	170mA		
Boom pole length	3.0M	4.5M	6.0M
Boom pole raise time (adjustable) ³	1.2 Sec	3 Sec	3 Sec
Manual override	6mm Allen key-operated from outside of the unit		
Maximum number of operations per day	3000		
Duty cycle - mains present ^{4 5}	80%		
Operations in standby with 7Ah battery			
Half day ⁶	3000 ⁷		
Full day ⁶	3000 ⁷		
Collision sensing	Electronic		
Operating temperature range	-20°C to 55°C		
Receiver code storage capacity	500 Transmitter buttons		
Receiver frequency	433.92 MHz		

TABLE 12

1. Can operate off a solar supply, consult Centurion Systems (Pty) Ltd for assistance
2. Battery capacity can be increased for longer standby times. (Battery capacity \neq 33Ah unless charger is upgraded)
3. Boom-pole raise and lower-times are both individually configurable to suit individual installation requirements
4. Based on 25°C ambient temperature and unit not in direct sunlight
5. Based on an output torque of less than 50% of rated torque
6. Based on basic operator excluding closing-loop detector
7. Limited by daily usage
8. The model designation of the barrier is an indication of the maximum length of pole for the specific spring. In other words, **SECTOR II** 3m = maximum 3m pole; **SECTOR II** 4.5m = maximum 4.5m pole, etc. In other words, if you wish to fit a 4.5m pole, a **SECTOR II** 4.5m/6m with corresponding spring must be used.

10.1.2. Barrier boom pole specifications

SECTOR II boom pole	3 Metre	4.5 Metre	6 Metre
Material and profile	Aluminium, round profile with plastic end cap		
Dimensions	Outside diameter 76.2mm; wall thickness 1.27mm		
Weight	800 kg/m		
Surface Protection, colour and markings	Epoxy-coated white with red reflective tape		
Mass of pole (kg)	2.4 kg	3.7 kg	4.9 kg

TABLE 13

10.1.3. Fuse protection

Item	Fuse type	Rating
Main controller		
Motor circuit	Automotive fuse ATO (25x7mm)	30A
Light circuit	5 x 20mm glass fuse	3A Fast blow
Auxiliary supply	Electronic limit	300mA
Charger		
Mains input	5 x 20mm glass fuse	3A Fast blow

TABLE 14

10.1.4. Certificate of compliance

This page has been left blank intentionally

10.2. Appendix 2. Changing the SECTOR II to a left-hand configuration

10.2.1. Changing over the internal spring assembly

Follow the steps below to change the barrier orientation as required by the site.

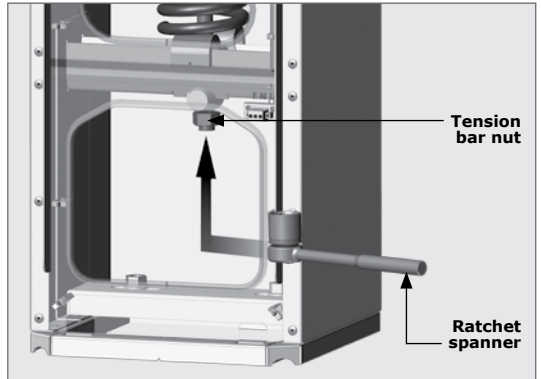

FIGURE 35

Removing the internal spring assembly

Step 1

Place the boom pole in the upright position. Remove the pole by removing the M8 nuts (refer back to Figure 15).

Step 2

Use a 24mm socket (4.5 and 6M boom) or a 17mm socket (3M boom) and a ratchet spanner to relax the tension on the spring by unwinding the nut in an anti-clockwise direction. Continue until there is no more tension in the spring whatsoever (Figure 36).

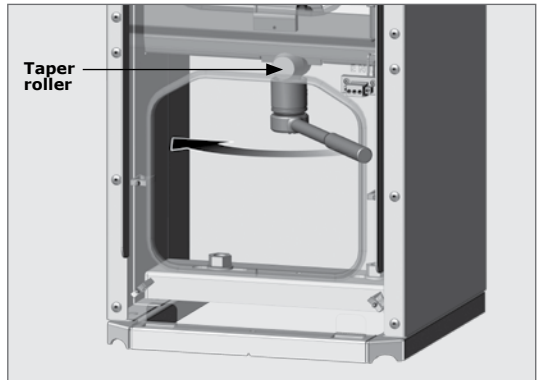

FIGURE 36

Step 3

When the spring is completely loose, rotate the taper roller at the bottom of the spring assembly 90° (Figure 37). This will allow you to lift the entire spring assembly out.

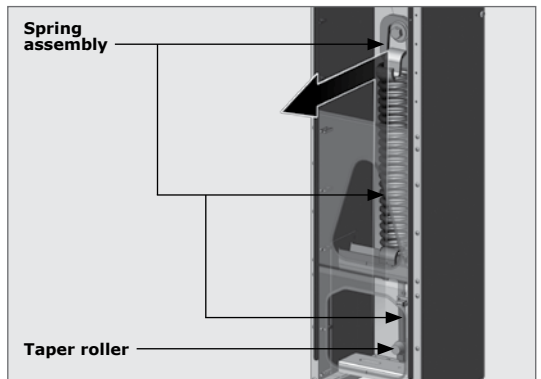

FIGURE 37

Reconfiguring the output shaft plate

Step 3

With the spring out of the way, use the 24mm socket and ratchet combination to loosen the spring bolt (Figure 38). This is held in place by a thread-locking adhesive and will require some considerable force to undo.



When unscrewing the spring bolt the output shaft plate will rotate in an anti-clockwise direction before locking into position. From this point it is possible to unscrew the bolt completely.

Step 4

Move the spring bolt and washers to the left-hand spring bolt position on the output shaft plate.

Use Loctite 290 (green thread locker) on the bolt-threads and use a torque wrench to tighten it to 45Nm. (See Figure 39 to see the new bolt position). The unit is now ready for the spring assembly to be re-installed.



Ensure that the spring orientation is correct before inserting the spring back into the cabinet.

Figures 41 and 42 depict the correct and incorrect spring orientations.

Step 5

Insert the spring assembly back into the cabinet (Figure 40), making sure that the orientation is correct according to Figure 41, and that the taper roller slides into the groove of the spring support bracket at the bottom of the cabinet as you hook the spring onto the bolt.

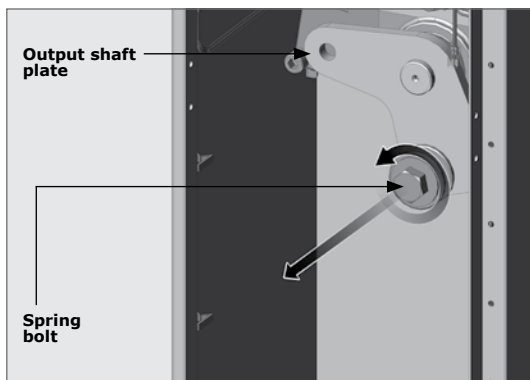

FIGURE 38

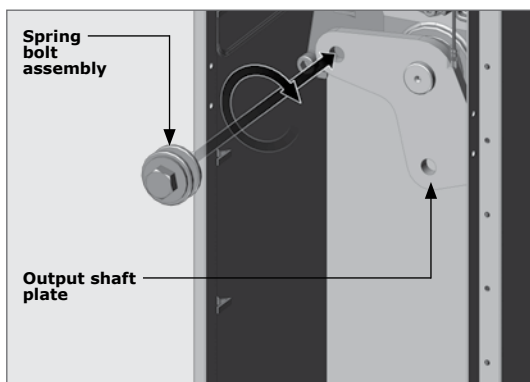

FIGURE 39

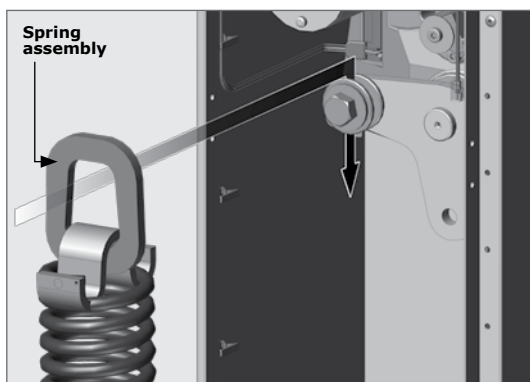

FIGURE 40

Ensuring the correct spring assembly orientation



The orientation of the top coil of the spring is critical with regards to the operation of the barrier. If it is the wrong way around, the spring will strike the output shaft plate which will impede its operation. See Figures 41 and 42 for the CORRECT spring orientation!

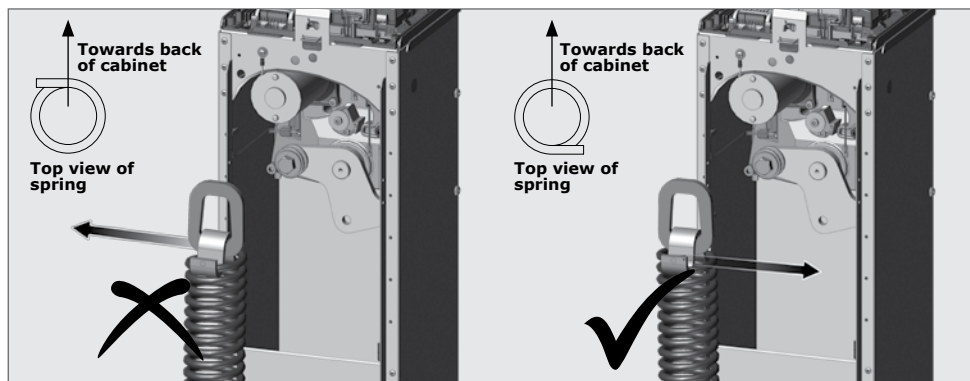

FIGURE 41. SPRING ORIENTATION OF A LEFT-HAND SECTOR II TRAFFIC BARRIER

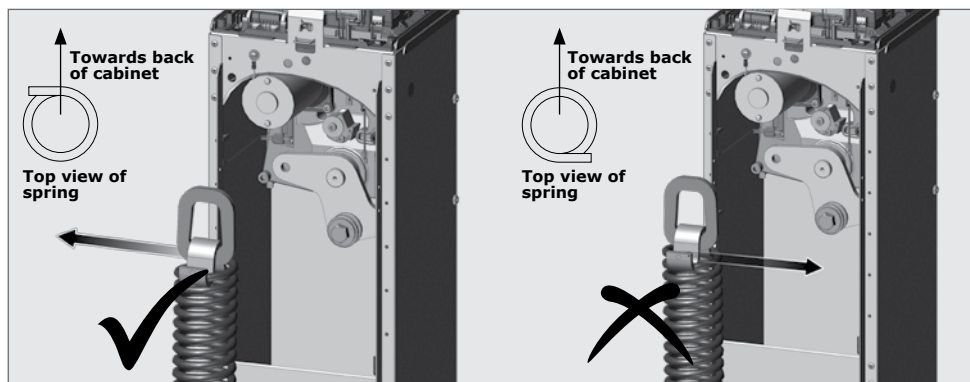

FIGURE 42. SPRING ORIENTATION OF A RIGHT-HAND SECTOR II TRAFFIC BARRIER



Remember to tighten the spring (but not fully) using the spring tension nut to avoid the spring falling out of position.

Removal and re-orientation of the boom pole coupler

Once the internal spring assembly has been reconfigured, the orientation of the boom pole coupler needs to change. Follow the steps below to obtain the correct orientation:

Step 1

Remove the M10 cap screw using an 8mm Allen key (not supplied) and washer from the inside of the coupling (Figure 43).

Step 2

Attempt to gently tap the coupler off. If this is not possible, then a coupler-puller may be required to remove the boom pole coupler if the taper lock has locked in tightly on the coupler.

The coupler-puller can be purchased from Centurion Systems (Pty) Ltd, or a similar one can be fabricated as shown in Figure 44.



If the coupler has been successfully removed without the need of the coupler puller, skip to Step 7.

Step 3

If using the coupler-puller kit, replace the original cap screw with the black M10x35 cap screw supplied in the coupler-puller kit.

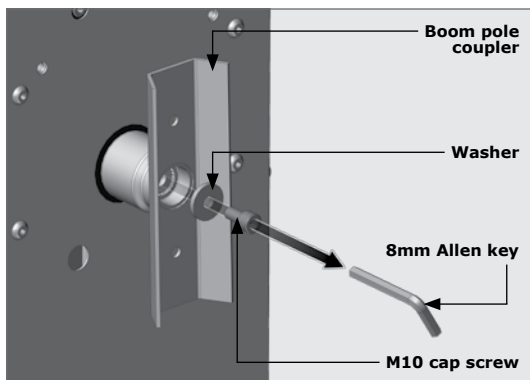

FIGURE 43

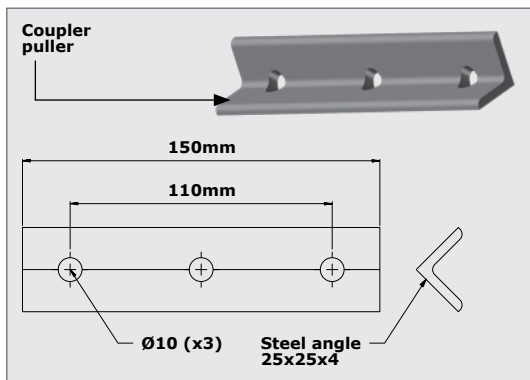

FIGURE 44

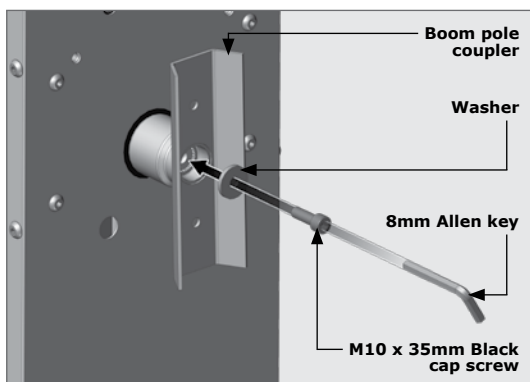

FIGURE 45

Step 4

Fit the coupler-puller to the boom pole coupler with the two M8 bolts and nuts provided in the coupler-puller kit (Figure 46).

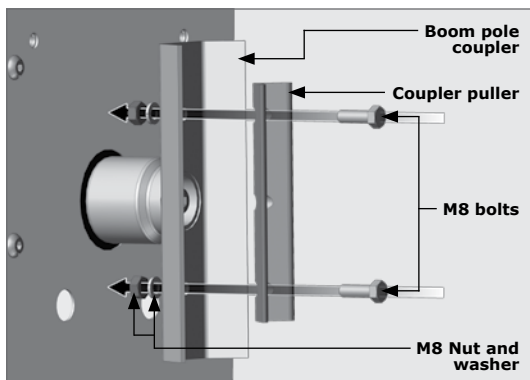

FIGURE 46

Step 5

Using an Allen key, unscrew the cap screw fitted in the middle of the shaft, which is reached through the middle hole in the coupler-puller. As the cap screw comes out it will push against the coupler-puller and pull the coupling off of the output shaft.

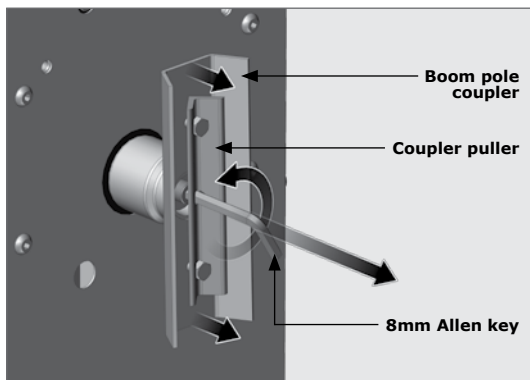

FIGURE 47

Step 6

Remove the coupler-puller components from the coupler.

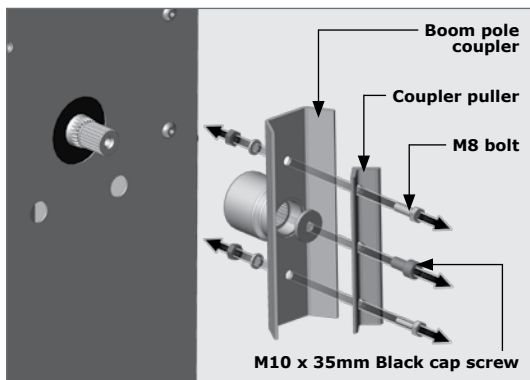

FIGURE 48

Step 7

Refit the coupler so that the pole will be vertical when the drive arm is at the top (Figure 49). If the drive arm is not at the top when the pole is in the vertical position, move the drive arm to this position by hand. The splines of the shaft will need to be aligned as precisely as possible, even though there is some adjustment provided for it in the linkage (Section 3.2).

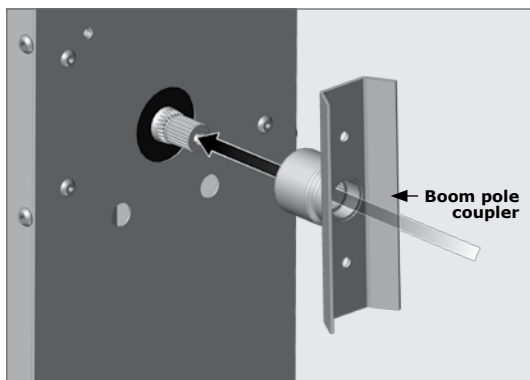

FIGURE 49

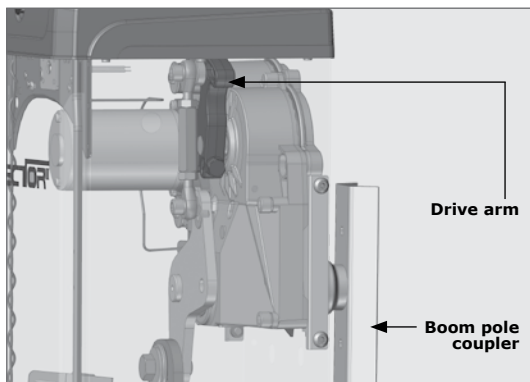

FIGURE 50

Step 8

Replace the washer and original cap screw in the centre of the shaft.

Step 9

Tighten the cap screw with the Allen key until the coupler is fastened tightly in position.

Continue with the installation as per 'Section 3.2. Fitting and levelling the boom pole'.

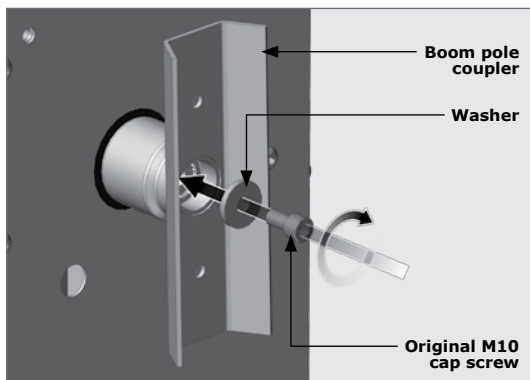

FIGURE 51

10.3. Appendix 3. Adjusting limits for Fail-safe Mode

The standard **SECTOR II** is supplied in Fail-safe Mode, meaning that the boom can be moved from the raised or lowered positions without requiring a manual override.

Alternatively, the operator can be configured so that, when mains power is present, the boom pole cannot be lifted or forced down but, in the event of a power-failure, the pole can be operated by hand. This can be set in the menu system (Menu 5.1).

In certain circumstances when the **SECTOR II** needs to be in 'Locked Mode', (meaning that the boom pole cannot be raised, or lowered, by hand), it will require use of the 6mm Allen key (provided) in the manual override slot to raise, or lower, the boom pole.



Ensure all power to the SECTOR II is OFF by switching off both the AC and DC isolator switches.

To convert the locking stops from Fail-safe Mode to Lock Mode, the stopper screw needs to be unscrewed using a T30 TORX extended length bit, a 1/4" ratchet spanner and appropriate ratchet adaptor. Rotate the locking stop to the locked position, insert the screw and tighten using the aforementioned tools.

The following figures show the endstops in their locked and unlocked (fail-safe) positions respectively.

Top limit

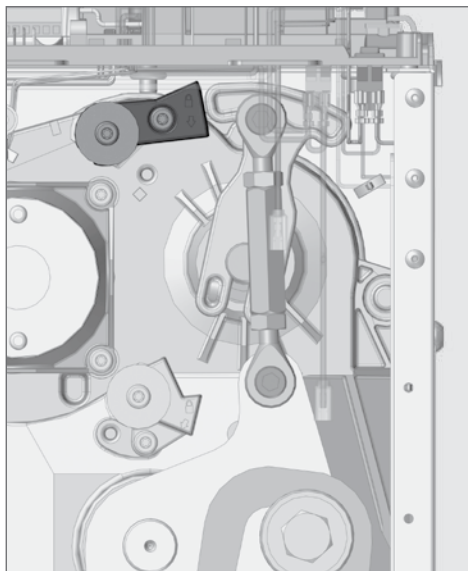

FIGURE 52. TOP LIMIT ENDSTOP IN THE STANDARD (FAIL-SAFE) POSITION

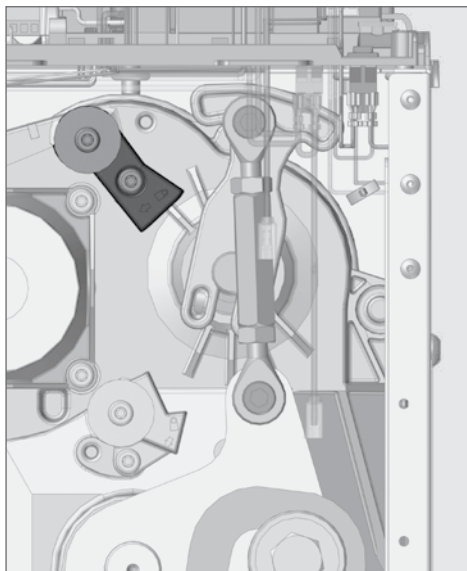

FIGURE 53. TOP LIMIT ENDSTOP MOVED DOWN (LOCKED POSITION AT TOP)

Bottom limit

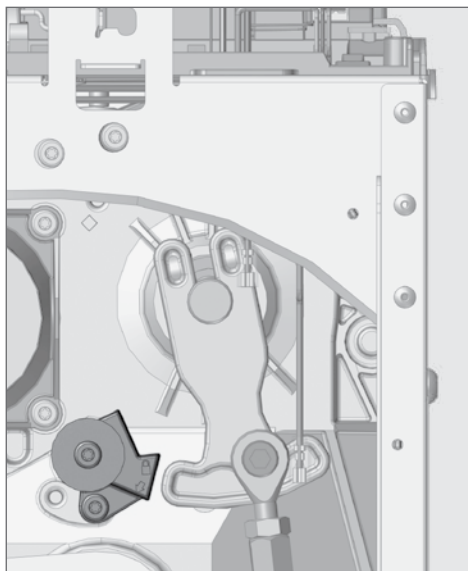

FIGURE 54. BOTTOM LIMIT ENDSTOP IN THE STANDARD (FAIL-SAFE) POSITION

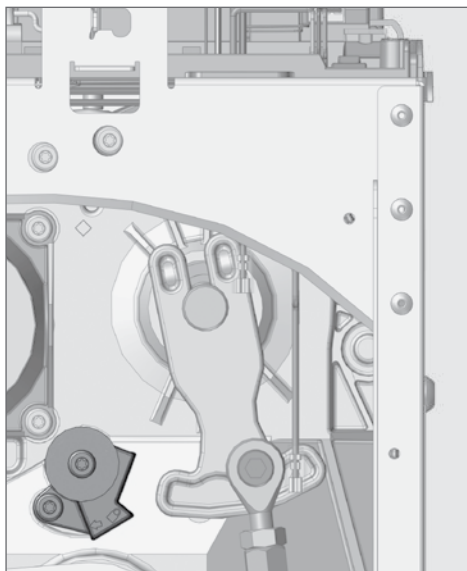

FIGURE 55. BOTTOM LIMIT ENDSTOP MOVED DOWN (LOCKED POSITION AT TOP)

Fail-safe/Lock Mode

When the barrier is in Fail-safe Mode, the boom pole can be manually moved by hand.

In Lock Mode, the boom pole is locked in the raised or lowered position and cannot be moved by hand.

These configurations are implemented by setting the top and bottom locking stops on the gearbox in different positions. (indicated in Figure 56)

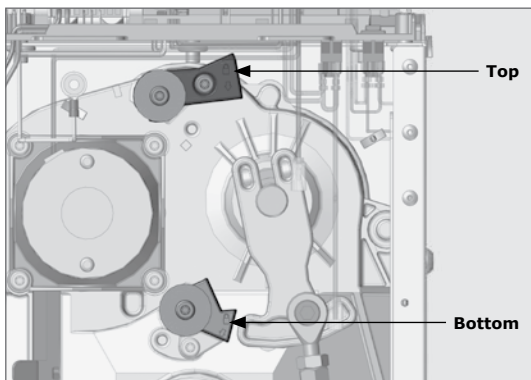

FIGURE 56

- For a right-hand boom to be placed in Lock Mode in the lowered position, position the top stopper as shown in Figure 57 (similarly for the left-hand raised locked position)

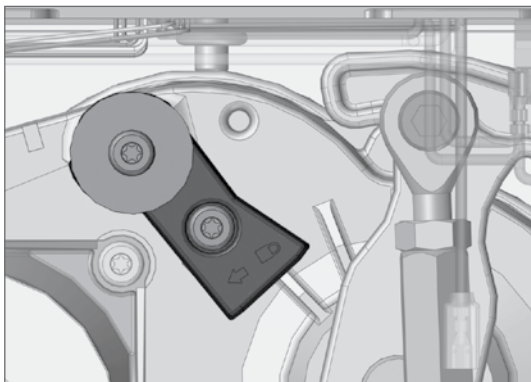

FIGURE 57. LOCK MODE POSITION (TOP)

- For a right-hand boom to be placed in Lock Mode in the raised position, position the top stopper as shown in Figure 58 (similarly for the left-hand lowered locked position)

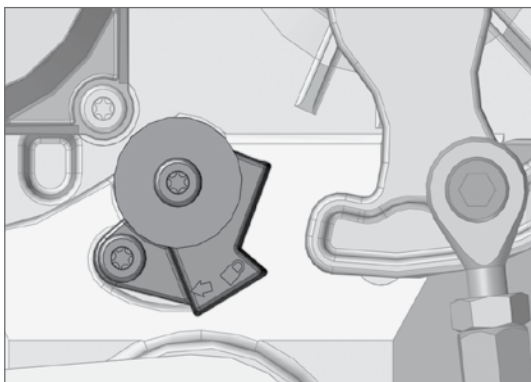

FIGURE 58. LOCK MODE POSITION (BOTTOM)

10.4. Appendix 4. FLUX 11-Pin loop detector installation

10.4.1 Single 11-pin loop detector

The **SECTOR II** is suited for use with different loop detector types, including 11-pin loop detector modules. The 11-pin base unit screws down through the tray, into the chassis.

Step 1

Screw the 11-pin base onto the electronics tray (Figure 60 and 61).

Step 2

Run the TWISTED loop wires up the inside of the enclosure through the wiring clips to the FLUX 11-pin unit.

Step 3

Wire the loop wires into the FLUX 11-pin unit.

Step 4

Wire the FLUX 11-pin into the **S-SERIES** controller using the supplied loop wire harness, following the wiring diagram shown in Figure 62.

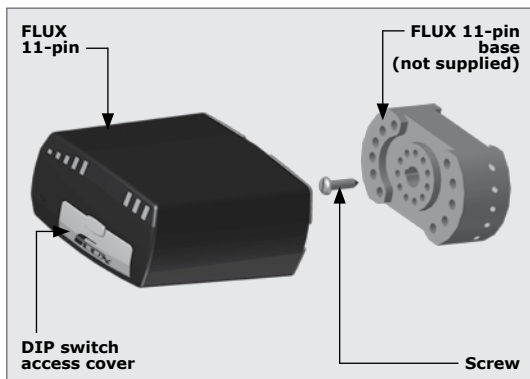

FIGURE 59

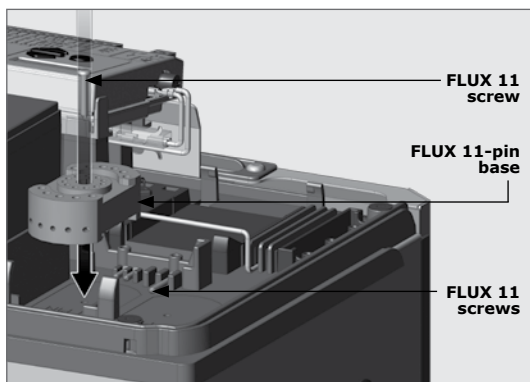

FIGURE 60

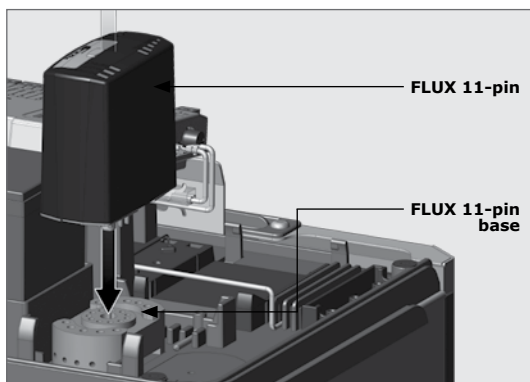

FIGURE 61



This wiring diagram assumes that a CENTURION FLUX loop detector is being used. If another brand of loop detector is being used, please refer to the documentation that accompanied the detector as there might be differences in how it should be connected.

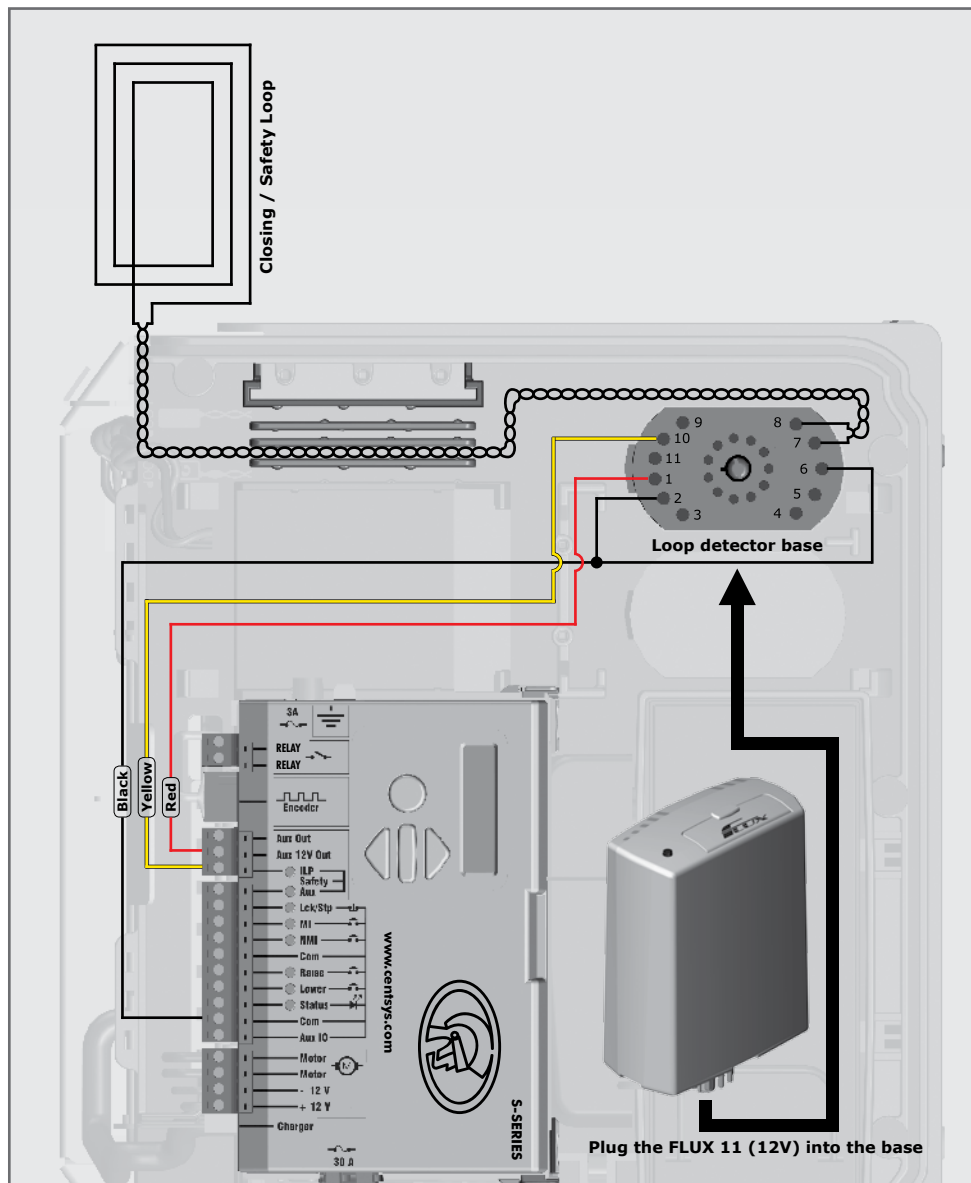

FIGURE 62. WIRING THE FLUX 11-PIN AS A CLOSING / SAFETY LOOP

If only one FLUX 11-pin loop detector is required for the installation, continue with the installation as per **'Section 5 - Basic controller setup'**.

Should a second FLUX 11-pin loop detector be required, continue to the next step.

DIP switch settings:

For the settings and descriptions, see the pocket-guide provided with the FLUX 11-pin.

10.4.2 Dual 11-pin loop detector

In some operating modes, a barrier may require two FLUX 11-pin loop detectors. A typical application for a double loop system is where both a safety and a free-exit loop is required. The following steps detail the process:

Step 1

Having already installed the first 11-pin loop detector, screw the second 11-pin base onto the electronics tray (Figure 64 and 65).

Step 2

Run the TWISTED loop wires up the inside of the enclosure through the wiring clips to the second FLUX 11-pin unit. Take note of the channels provided to separate each of the twisted pairs for the relevant loop detector (Figure 64).

Step 3

Wire the loop wires into the second FLUX 11-pin unit.

Step 4

Wire the second FLUX 11-pin into the second FLUX 11-pin into the **S-SERIES** controller using the supplied loop wire harness, following the wiring diagram shown in Figure 66.

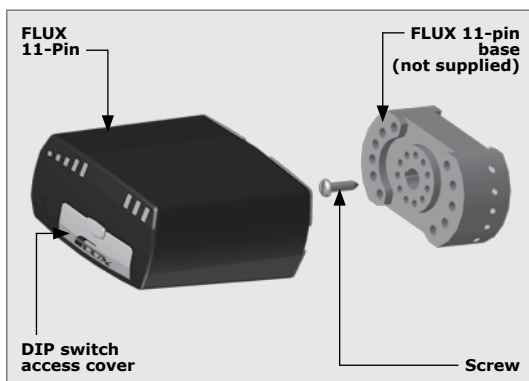

FIGURE 63

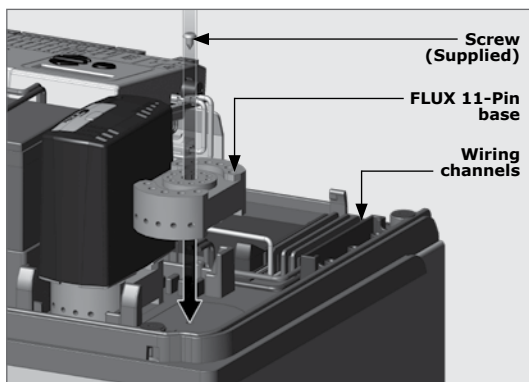

FIGURE 64

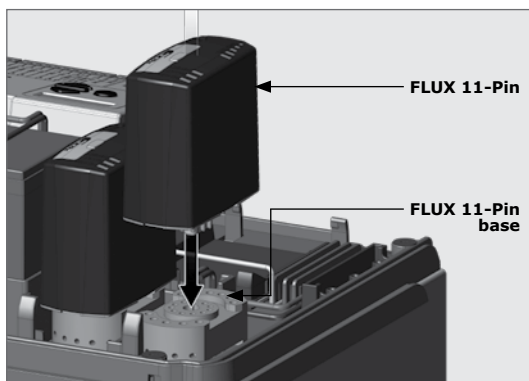

FIGURE 65



This wiring diagram assumes that a CENTURION FLUX loop detector is being used. If another brand of loop detector is being used, please refer to the documentation that accompanied the detector as there might be differences in how it should be connected.

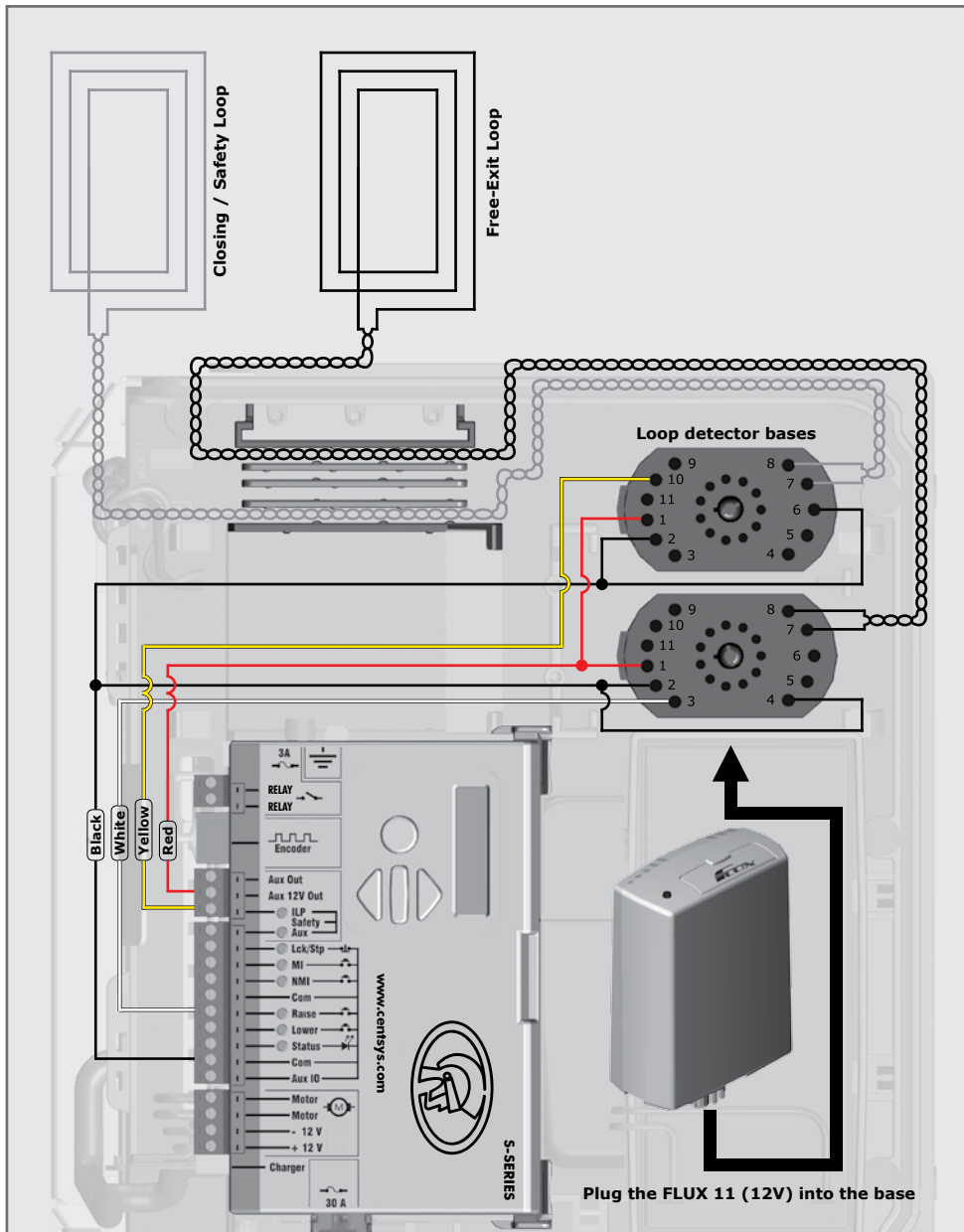

FIGURE 66. WIRING THE FLUX 11 WITH A DUAL LOOP CONFIGURATION

Continue with the installation as per 'Section 5 - Basic controller setup'.

10.5. Appendix 5. Safety beam installation

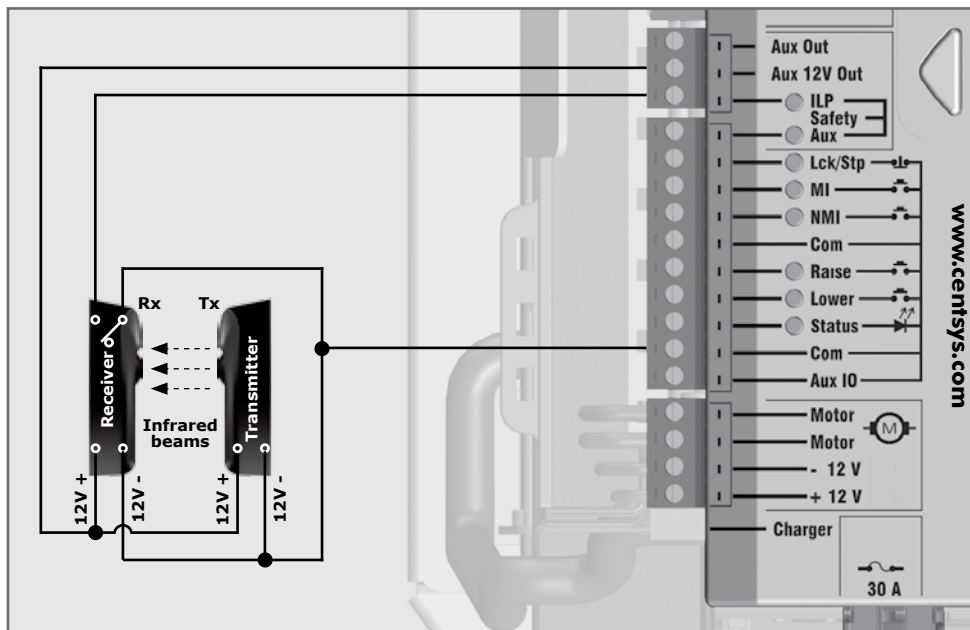

FIGURE 67. SECTOR II - I5 IR BEAMS SHOWN

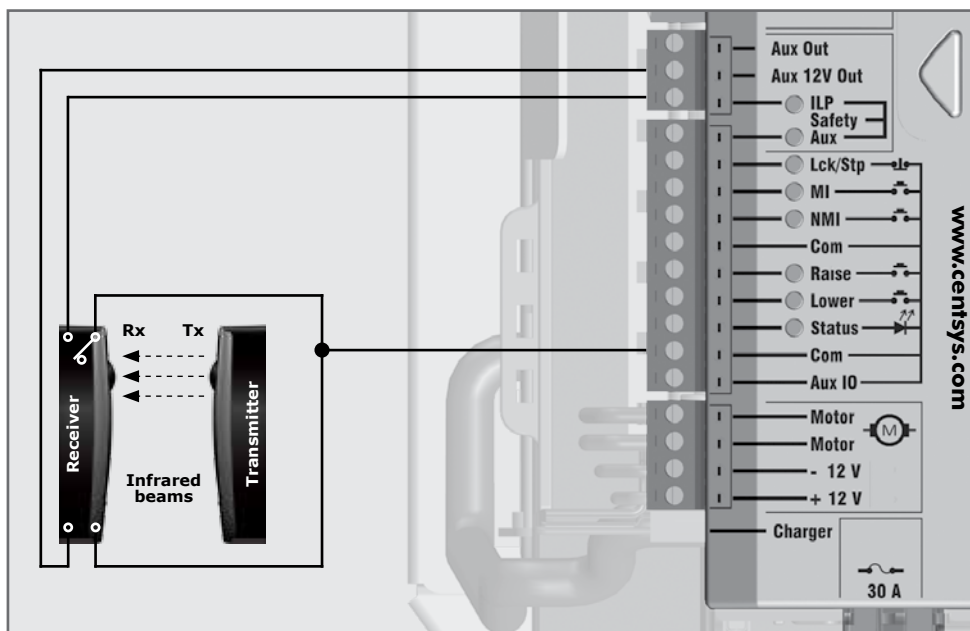

FIGURE 68. SECTOR II - PHOTON IR BEAMS SHOWN

10.6. Appendix 6. Wiring diagrams for installation modes

10.6.1. Simplex Mode

These modes relate directly to the installation modes shown in Menu 4.

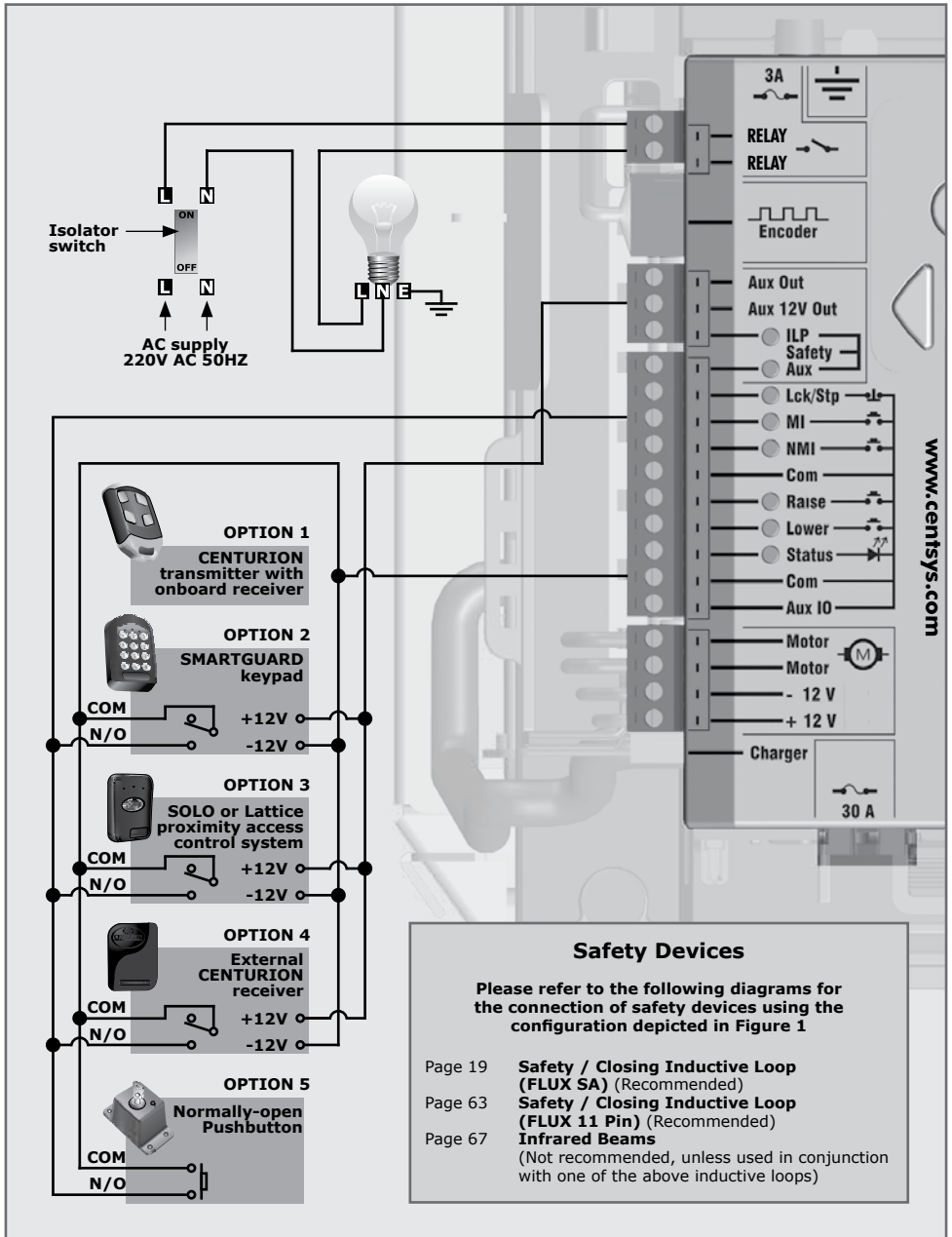

FIGURE 69. SECTOR II - SIMPLEX MODE

10.6.2. Complex Mode (Option 1)

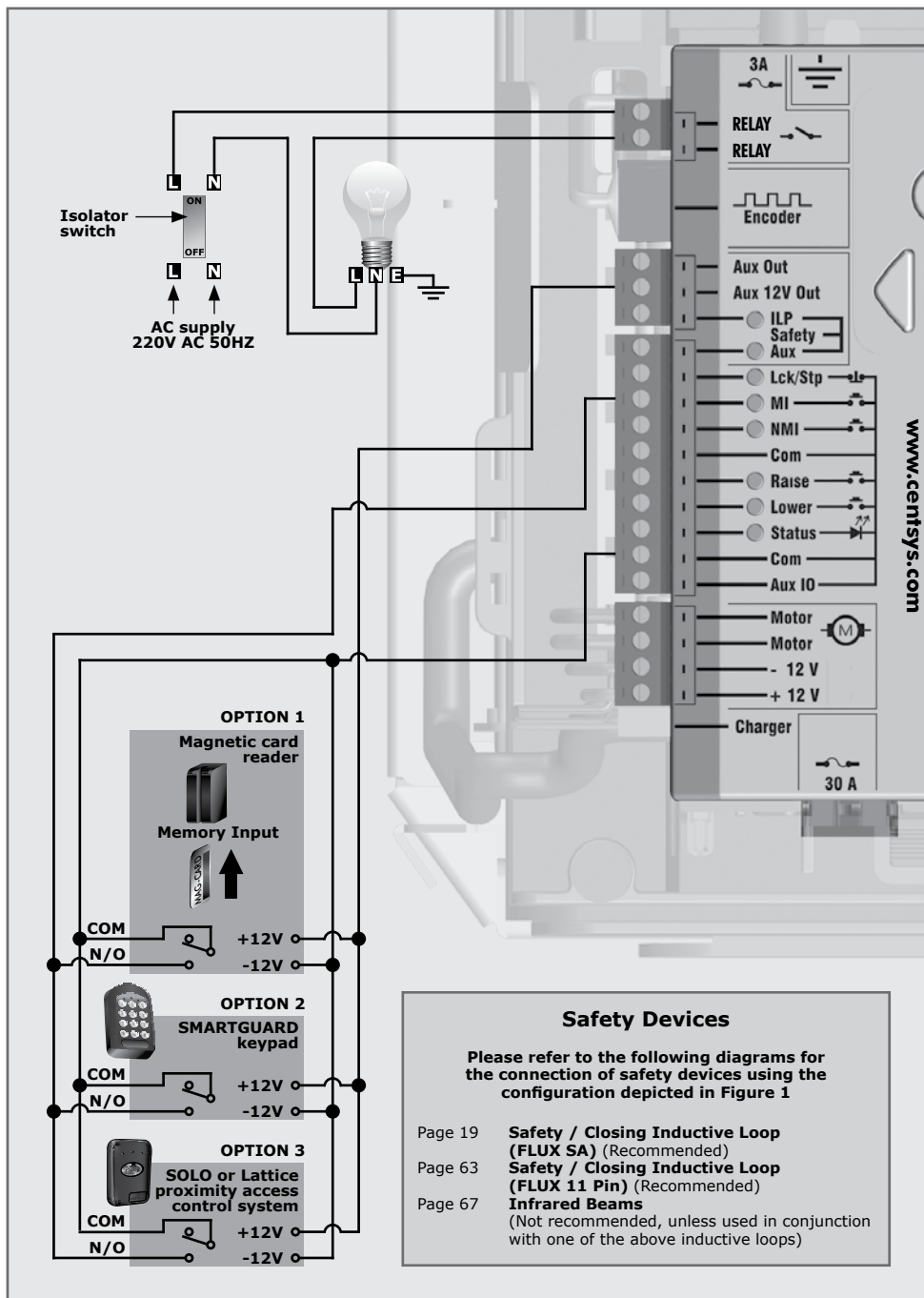

FIGURE 70. SECTOR II - COMPLEX MODE (OPTION 1)

10.6.3. Complex Mode (Option 2 - Ticket vendors)

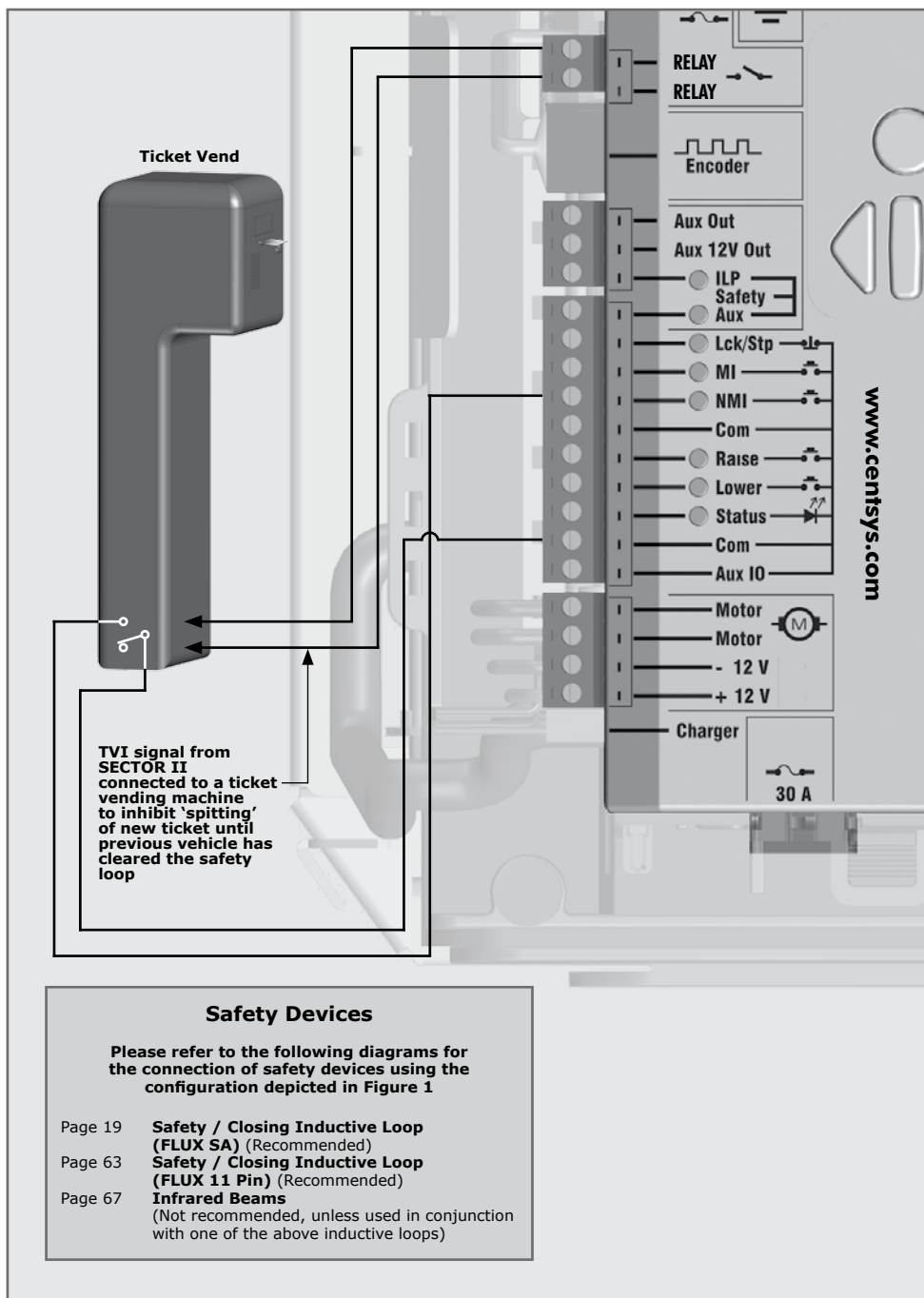

FIGURE 71. SECTOR II - TICKET VENDORS

10.6.4. Uni-directional traffic

The free-exit function allows vehicles to exit a facility by automatically raising the barrier. It is recommended that an inductive loop detector be used to activate the free-exit facility. Infrared beams can be used for this function but a loop detector is preferred.

The free-exit loop will raise the barrier and the closing loop will be used to lower the barrier the moment the vehicle has exited. Select the relevant direction on the control card within the loop detector menu, refer to Section 7.

10.6.5. Bi-directional traffic

This allows access for traffic from both directions in a single lane. In this case the same barrier provides access control for vehicles entering and free-exit for vehicles exiting. A triggering device can be used for the access function and the loop for the free-exit function.

The free-exit loop must be mounted close enough to the closing loop so that the vehicle exiting is still present on this loop when it reaches the closing loop. However, these must not be too close together (a distance greater than 1000mm is required), or magnetic interference will be caused.

The free-exit loop will raise the barrier and the closing loop will be used to lower the barrier the moment the vehicle has exited. Select the relevant direction on the control card within the Loop Detector Menu refer to Section 7.

10.7. Appendix 7. Factory default settings

South African standard profile – ZA

Parameter description	Unit	Minimum	Default	Maximum
Menu 1 - not applicable				
Menu 2				
Raising collision force	Level	1	3	Max
Lowering collision force	Level	1	3	Max
Collision count	Collisions	1	4	255
Alarm output	B, T, A, X, L ¹		Buzz	
LCK as ESTOP	Yes or No		No	
Menu 3				
Autolower status	On/Off		Off	
Autolower time	Mm:ss	00:00	00:30	4:00
Autolower override time	Mm:ss	00:00	00:01	00:15
Autolower on raised	On/Off		On	
Autolower on partly raised	On/Off		On	
Autolower on partly lowered	On/Off		Off	
Menu 4				
Modes of Operation	S, C, P, SP		CMX	
Menu 5				
Lock when raised	Yes/No		No	
Lock when lowered	Yes/No		No	
Holding force	%	10%	50%	100%
Raise when mains fail	On/Off		On	
Pre-raising delay time	Mm:ss	00:00	00:00	01:05
Pre-lowering delay time	Mm:ss	00:00	00:00	01:05
Raising speed	Deg/sec	10 deg/sec	37 deg/sec	Max
Lowering speed	Deg/sec	10 deg/sec	37 deg/sec	Max
Ramp-up distance	Deg	3 deg	7 deg	15 deg
Ramp-down distance	Deg	3 deg	7 deg	15 deg
TRG stop distance	Deg	5 deg	10 deg	30 deg
Loop stop distance	Deg	5 deg	10 deg	30 deg
Crawl distance	Deg	1 deg	1 deg	5 deg
Torque limit	A	5A	15A	15A

Parameter description	Unit	Minimum	Default	Maximum
Menu 6				
ILAC control	On/Off		Off	
Rollback time	Mm:ss	00:01	00:10	00:15
FRX loop direction	Uni/bi		Uni	
Presence alarm status	On/Off		Off	
Presence time	Mm:ss	01:00	01:00	04:00
Break-in alarm	On/Off		Off	
Alarm output	L, X, A, T, B		LED	
Menu 7				
TVI output function	TVI or CUR		TVI	
TVI output polarity	N/O or N/C		N/C	
Light timer	Hh:mm:ss	00:02:00	00:02:00	09:59:59
Menu 8 – Not applicable				
Menu 9				
Diagnostic screen status	On/Off		Off	
Round test button	On/Off		On	
Menu 10				
Delete not present	On/Off		Off	
Autolearn	On/Off		Off	
Tx menu lock	On/Off		Off	
Onboard receiver	On/Off		On	

TABLE 15

10.8. Appendix 8. Terminal descriptions

12V +	Positive battery connection. Tip: Battery terminal normally indicated as + or red terminal
12V -	Negative battery connection. Tip: Battery terminal normally indicated as - or black terminal
Motor	Motor output – connects to the thick blue motor wire
Motor	Motor output – connects to the thick black motor wire
Aux IO	The Aux IO terminal provides an open collector output which can be used for alarm or auto-function purposes. If the collision alarm output or the Presence Alarm output has been configured to Aux IO , then the negative of the alarm device must be connected to this terminal. The positive of the alarm device must be connected to the Aux 12V Out terminal. Similarly, if Aux IO is auto-activated via a ChronoGuard auto-activation Time-period, the device being switched (typically a 12V relay) must be powered from the Aux 12V Out terminal, and have its negative switched by Aux IO . If the Aux IO has not been selected as either an alarm-indicator output or auto-activated output, the Aux IO terminal will behave as a 'Com' (i.e. battery negative) termination point. All trigger signals, etc., have their return path to one of the Com terminals
Com	The common termination point. All trigger signals, etc., have their return path to one of the Com terminals
Status	External boom status indication. (A low-current output signal). An output terminal which provides a low-current drive (approximately 4,5V DC, 20mA) to a LED which can be used to indicate the boom status remotely. If more than three LEDs are required, it is necessary to fit the CP78 multi-LED driver card
Aux	The lowering input. (A normally-open potential-free input). Momentarily connecting this input to Com will cause the boom-pole to immediately lower regardless of which position it is in, unless it is already fully lowered
FRX	The raising input. (A normally-open potential-free input). Momentarily connecting this input to Com will cause the boom pole to immediately raise regardless of which position it is in, unless it is already fully raised
Com	A second common termination point. All trigger signals, etc.; have their return path to one of the Com terminals
NMI	The non-memory input. (A normally-open potential-free input). Momentarily connecting (e.g. using a normally-open pushbutton or the Common and NO (normally-open) of a relay contact) the NMI to Com will cause the boom pole to raise, stop or lower depending on the operating mode selected

MI	The memory input. (A normally-open potential-free input). The memory input counts and stores each trigger impulse. The boom pole will stay raised until the same number of closing signals is applied to the closing input, such as the closing loop. This input is typically used in conjunction with the Complex (CMX) Mode of Operation
LCK/STP	Holiday lockout or boom stop input. (A normally-closed potential-free input). For as long as a connection between this input and Com is maintained the controller will behave normally, but when the connection to Com is broken all inputs are inhibited
ILP	The inductive loop detector input. (A normally-closed potential-free input). As long as a connection between this input and Com is maintained the controller will behave normally. When this connection is broken, i.e. a vehicle drives onto the inductive ground loop, it will prevent the barrier from lowering if it is stationary, and will stop and raise the barrier if it is lowering
Aux 12V Out	Auxiliary power connection. Provides +12V DC supply for auxiliary equipment such as a radio receiver, photo cells, etc. It is electronically limited to 300mA
RELAY/ RELAY	Ticket vending interlock. These two terminals provide a normally-open potential-free contact which is generally used to introduce an electronic "lock" to ticket vending devices, meaning that tickets cannot be dispensed while the boom pole is raised or raising. Alternatively, the terminals can be used to connect a courtesy or security light which will illuminate whenever the barrier is operated. Com will cause the boom pole to raise, stop or lower depending on the operating mode selected. Each trigger impulse received will cause the barrier to react accordingly

TABLE 16

10.9. Appendix 9. Ancillary installation equipment

A number of additional devices are available which can be interfaced with the **SECTOR II** traffic barrier to increase security or otherwise enhance the installation.



FIGURE 72. BREAKAWAY COUPLING

Description:

Pole hinges away from barrier if accidentally knocked, reducing the chance of damage.



FIGURE 73. JACK-KNIFE ASSEMBLY

Description:

Used in cases where there are height restrictions such as undercover parking

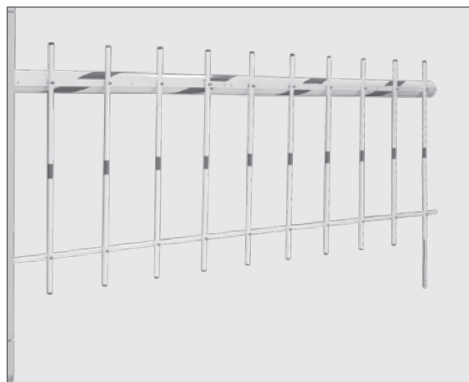

FIGURE 74. TRAPEX

Description:

Stops pedestrians from circumventing the **SECTOR II**. Available for 3m and 4.5m boom poles.

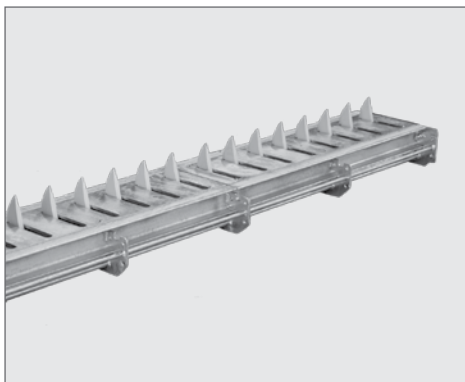

FIGURE 75. CLAWS - FLUSH MOUNT

Description:

Add real security with seamless integration with the **SECTOR II**. Available in 1m and 1.5m sections.



FIGURE 76. CLAWS - SURFACE MOUNT

Description:

Add real security with seamless integration with the **SECTOR II**. Available in 1m and 1.5m sections.



FIGURE 77. FLUX 11-PIN

Description:

Required to enable the free-exit or the closing / safety loop facilities



FIGURE 78. FLUX SA

Description:

Required to enable the free-exit or the closing / safety loop facilities



FIGURE 79. MIDI TRAFFIC LIGHT

Description:

Visually indicates when it is safe for a vehicle to proceed into or out of an access controlled area

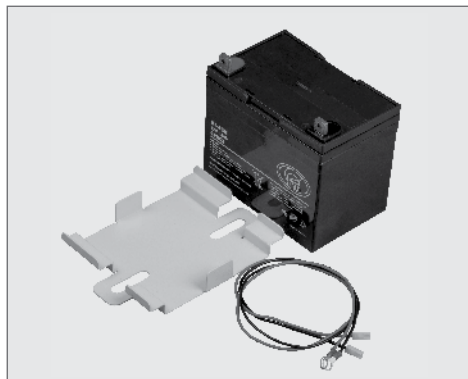

FIGURE 80. 33AH BATTERY KIT

Description:

A 33Ah battery can supplement or replace the 7Ah battery for extended battery back-up. Requires a bracket and harness to connect the 33Ah battery to the existing harness.

Other Ancillaries:

- Keypad
- SOLO
- Lattice
- G-SWITCH-22
- SMARTGUARDair
- G-SPEAK
- SupaHelix
- NOVA Remote
- NOVA Receiver



Ancillary product documentation is available for download at www.centsys.com



Connect with us on:

 facebook.com/centurionsystems

 YouTube.com/centurionsystems

 [@askcenturion](https://twitter.com/askcenturion)

Subscribe to the newsletter: www.centsys.com/subscribe

**Call Centurion Systems (Pty) Ltd • South Africa
Head Office: +27 11 699 2400**

**Call Technical Support: +27 11 699 2481
Monday to Friday: from 07h00 to 18h00 (GMT+2)
Saturday: from 08h00 to 16h30 (GMT+2)**

E&OE Centurion Systems (Pty) Ltd reserves the right to change any product without prior notice

All product and brand names in this document that are accompanied by the ® symbol are registered trademarks in South Africa and/or other countries, in favour of Centurion Systems (Pty) Ltd, South Africa.

The CENTURION and CENTSYS logos, all product and brand names in this document that are accompanied by the TM symbol are trademarks of Centurion Systems (Pty) Ltd, in South Africa and other territories; all rights are reserved.

We invite you to contact us for further details.



**Doc number: 1246.D.01.0001_1
SAP code: DOC1246D01**

www.centsys.com