

*AUTOMATION FOR STREET BARRIERS*

## **GARD 4** SERIES



INSTALLATION MANUAL

**G4040Z - G4040IZ**

**“IMPORTANT SAFETY INSTRUCTIONS FOR INSTALLATION”**

**“CAUTION: IMPROPER INSTALLATION MAY CAUSE SERIOUS DAMAGE, FOLLOW ALL INSTALLATION INSTRUCTIONS CAREFULLY”**

**“THIS MANUAL IS ONLY FOR PROFESSIONAL INSTALLERS OR QUALIFIED PERSONS”**



## 1 Legend



This symbol indicates sections to be read with particular care.



This symbol indicates sections concerning safety.



This symbol indicates notes to communicate to users.

## 2 Destination and limits of use

### 2.1 Destination

The GARD 4 automatic barrier was designed for use in private or public car parks, in residential areas or in highly trafficked areas.



The use of this product for purposes other than as described above and installation executed in a manner other than as instructed in this technical manual are prohibited.

### 2.2 Limits of use

Passage width of up to 3.75 meters with a 2- to 6-second aperture time.

## 3 Standard followed

Came Cancelli Automatici is ISO 9001:2000 and ISO 14001 Quality and Environmentally certified. Came entirely designs and manufactures its products in Italy.

The product in question compliant to the following legislation: *see Declaration of Compliance.*

## 4 Description

### 4.1 Gearmotor

GARD 4 was designed and manufactured by CAME CANCELLI AUTOMATICI S.p.A. and is compliant with safety regulations in force. Guaranteed 24 months if not tampered with.

The cabinet is made of 2.5 mm painted galvanized steel or 2 mm AISI 304 satin-finish stainless steel. Inside the cabinet, the electromechanical gearmotor operates with a container for electric board and transformer. Built with a anti-shearing safety system, it includes a safety contact in the inspection hatch lock and in the emergency release lock.

There are two versions of the GARD 4 model:

G4040Z - painted galvanized steel automatic barrier with a 24V DC gearmotor with control panel;

G4040IZ - satin-finish AISI 304 stainless steel automatic barrier with 24V DC gearmotor with control panel;

The GARD 4 automation system is supplied with the following accessories:

001 G03750 - L. 4m semioval aluminium bar, painted white, with slot cover and shock-resistant profile;

001 G03752 - L. 4m oval aluminium bar, painted white, with slot cover;

001 G03753 - Attachment flange for elliptical bar;

001 G02040 - Ø 40 (yellow) balancing spring;

001 G04060 - Ø 50 (green) balancing spring;

001 G06080 - Ø 55 (red) balancing spring;

002 LB38 - Board for the connection of three 12V-6Ah emergency batteries;

The following accessories are optional to the GARD 4 automation system:

001 G02801 - Flashing dome lamp;

001 G02802 - Support for mounting the photoelectric cell (DIR) onto the cabinet (not applicable to barriers with bar and rack and/or mobile foot);

001 G03751 - Emergency battery housing support;

001 G02803 - Luminous cord for movement signalling;

001 G02804 - Luminous cord connecting cable;

001 G02807 - Fixed barrier support;

001 G02808 - Mobile barrier support;

001 G02809 - Red reflector strips (package of 20);

001 G0465 - Painted aluminium rack in 2m modules;

**Important!** Check that the safety equipment and accessories are CAME originals; this is a guarantee that also makes the system easy to set up and upkeep.

## 4.2 Technical information

### GEARMOTOR

Power supply: 230V A.C. 50/60Hz  
 Motor power supply: 24V D.C. 50/60Hz  
 Max. absorption: 1.3A (230V) / 15A (24V)  
 Rated power: 300W  
 Max. torque: 600 Nm  
 Reduction ratio: 1/202

Opening time: 2÷6 s  
 Operative intermittence: intensive operation  
 Protection level: IP54  
 Weight: 55 kg  
 Insulation class: I

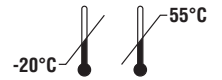

## 4.3 Parts description

### AUTOMATION UNIT

- 1) Upper dome
- 2) Bar beam plate
- 3) Bar fitting intermediate plate
- 4) Cover for semioval aluminium bar
- 5) Anti-shearing protection cover
- 6) Sheet-steel or stainless steel cabinet with galvanized and painted finish
- 7) Inspection hatch
- 8) Gearmotor
- 9) Lever
- 10) End stop unit
- 11) ZL38 Control panel

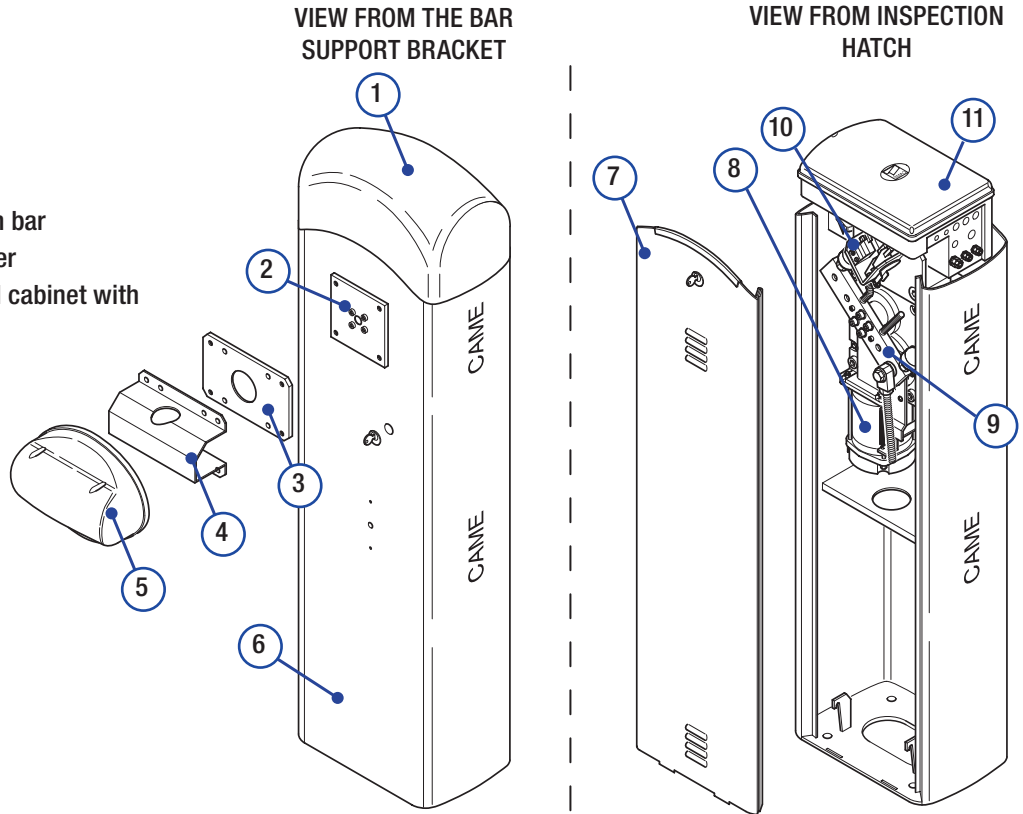

### ACCESSORIES

- 1) G03750 - Semioval aluminium bar, painted white L = 4 m.
- 2) G03752 - Oval aluminium bar, painted white L = 4 m.
- 3) G02040 - Ø40 (yellow) balancing spring
- 4) G04060 - Ø50 (green) balancing spring
- 5) G06080 - Ø55 (red) balancing spring
- 6) G0465 - Rack
- 7) G02802 - support for DIR photoelectric cells
- 8) G02803 - Luminous cord
- 9) G02807 - Fixed barrier support
- 10) G02808 - Mobile barrier support
- 11) G02809 - Adhesive reflector strips
- 12) G02801 - Flashing dome lamp
- 13) G03751 - Emergency battery housing support
- 14) G03753 - Attachment flange for elyptical bar

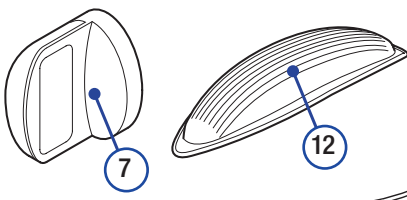
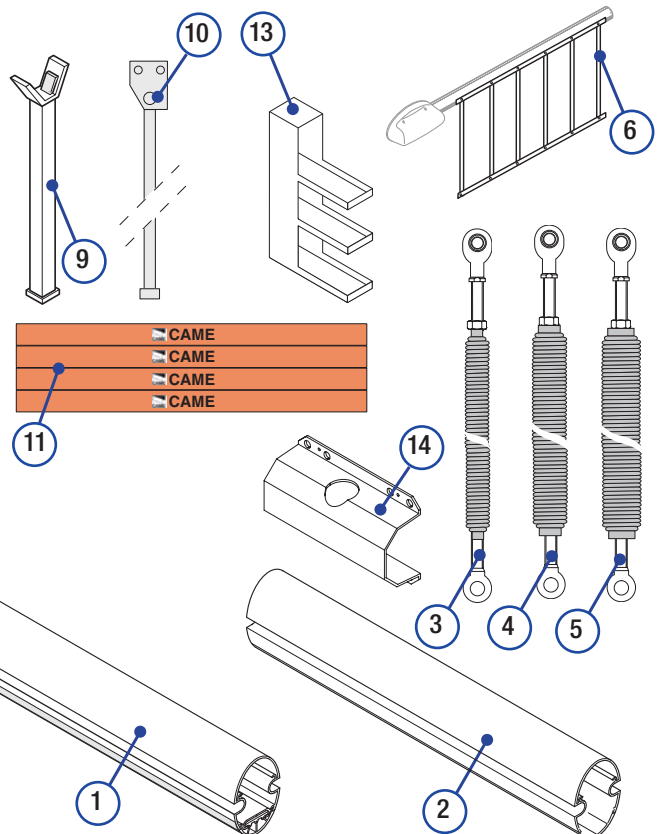

## 4.4 Size measurements

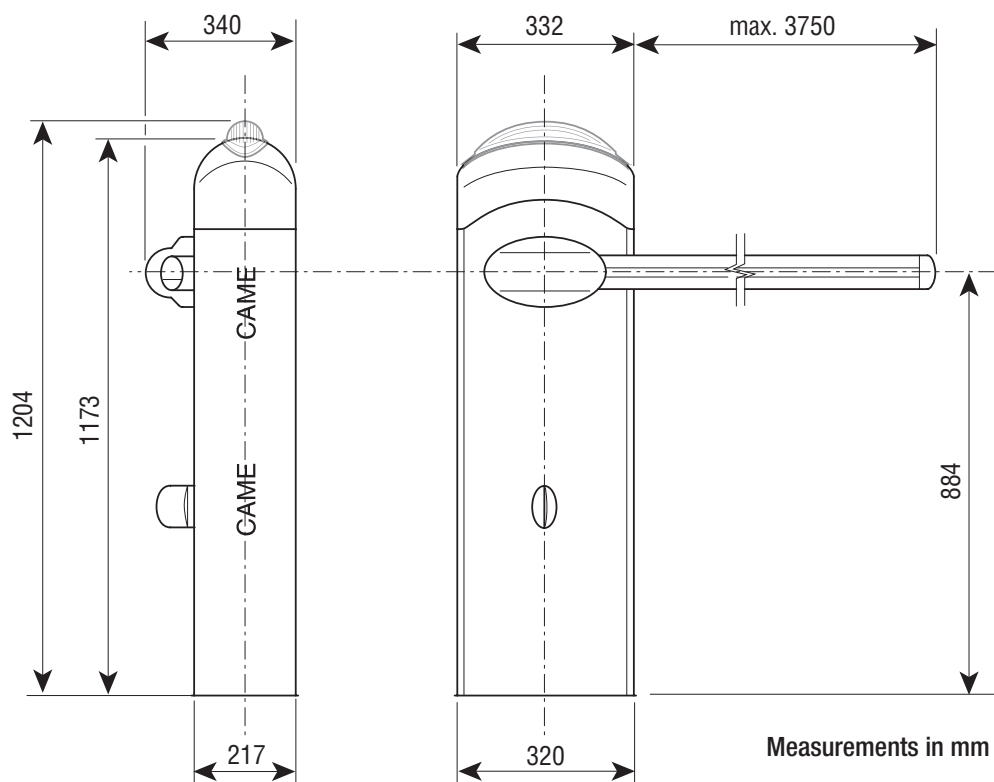

## 5 Installation

**⚠** Installation must be carried out by expert qualified personnel and in full observance of regulations in force.

### 5.1 Preliminary checks

**⚠** Before proceeding with the installation, it is necessary to:

- Make sure the area selected for the mounting of the base and for the unit itself presents no hazards;
- Provide for suitable omnipolar disconnection device with more than 3 mm between contacts to section power supply;
- ⚡ Connections inside the case made for protection circuit continuity are allowed as long as they include additional insulation with respect to other internal drive parts;
- Install suitable tubes and ducts for electric cable passage to guarantee protection against mechanical damage;

### 5.2 Tools and materials

Make sure all tools and materials necessary are within reach to install the edge in maximum safety, according to regulations in force. The following figure illustrates the minimum equipment for the installer.

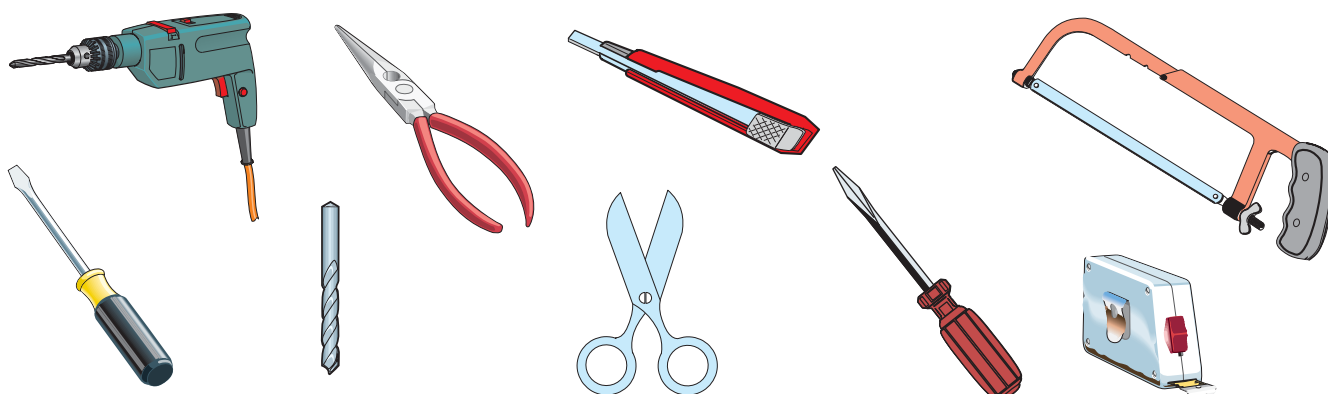

### 5.3 Cable list and minimum thickness

Connections	Type of cable	Length of cable 1 < 10 m	Length of cable 10 < 20 m	Length of cable 20 < 30 m
230V 2F power supply	FROR CEI 20-22 CEI EN 50267-2-1	3G x 1,5 mm <sup>2</sup>	3G x 2,5 mm <sup>2</sup>	3G x 4 mm <sup>2</sup>
Photoelectric cells TX		2 x 0,5 mm <sup>2</sup>	2 x 0,5 mm <sup>2</sup>	2 x 0,5 mm <sup>2</sup>
Photoelectric cells RX		4 x 0,5 mm <sup>2</sup>	4 x 0,5 mm <sup>2</sup>	4 x 0,5 mm <sup>2</sup>
24V power supply accessory		2 x 0,5 mm <sup>2</sup>	2 x 0,5 mm <sup>2</sup>	2 x 1 mm <sup>2</sup>
Safety and control devices		2 x 0,5 mm <sup>2</sup>	2 x 0,5 mm <sup>2</sup>	2 x 0,5 mm <sup>2</sup>
Antenna connection	RG58	max. 10m		
Metallic mass detector	(see documents provided with product)			

N.B.: An evaluation of the size of the cables with lengths other than the data in the table must be made based on the effective absorption of the connected devices, according to the instructions indicated by the CEI EN 60204-1 standards.  
For connections that require several loads on the same line (sequential), the size given on the table must be re-evaluated based on actual absorption and distances.

### 5.4 Standar installation

- |                                       |                                 |
|---------------------------------------|---------------------------------|
| 1 - GARD unit                         | 8 - Photoelectric cells         |
| 2 - Control panel                     | 9 - Fixed barrier support       |
| 3 - Aluminium bar                     | 10 - Magnetic sensor            |
| 4 - Red phosphorescent strips         | 11 - Photoelectric cell support |
| 5 - Luminous cord                     | 12 - Magnetic reader            |
| 6 - Movement-indicating flashing lamp | 13 - Column for reader          |
| 7 - Column for photoelectric cells    |                                 |

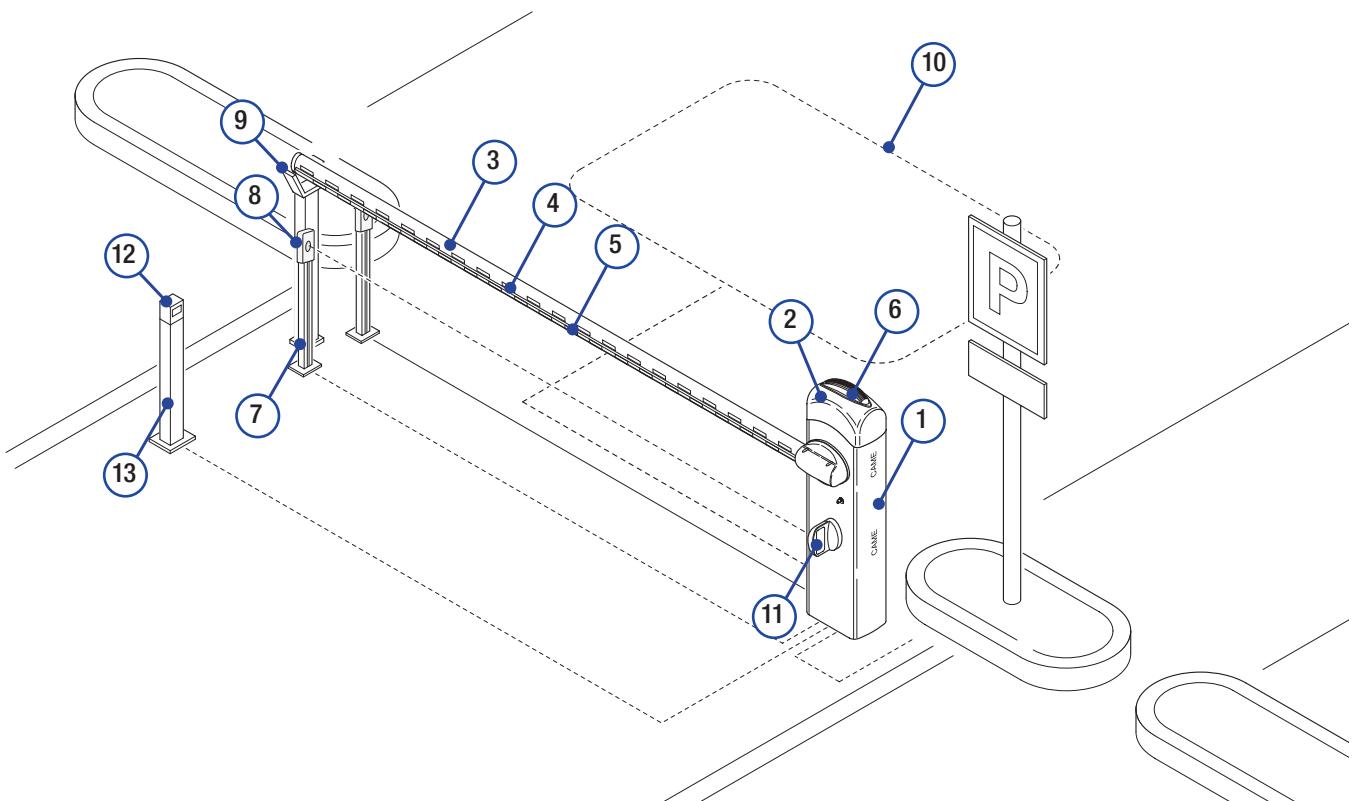

### 5.5 Fitting for unit base

**!** The following applications are only examples, as the space required for unit installation and the accessories vary depending on dimensions and therefore it is up to the installer to select the best solution.

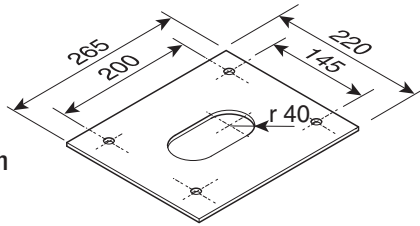

- Prepare a hole to house the fixing base and prepare sheath tubes from the branch pit for the connections.  
 N.B. the number of tubes depends on the type of system and the accessories you will hook up.

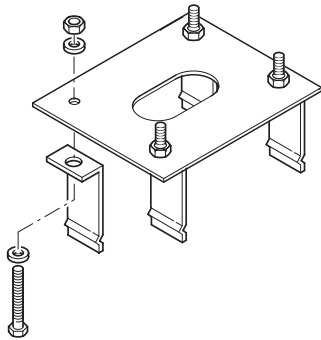
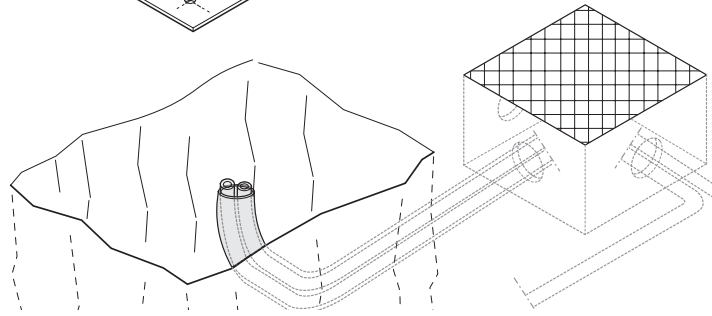

- Assemble the four anchoring clamps at the base.

- Fill the hole with concrete and immerge the clamps and the fixing base, paying particular attention to the sheath tube which must go through the hole at the base. The base must be perfectly level, clean and with the screw threads fully on the surface.

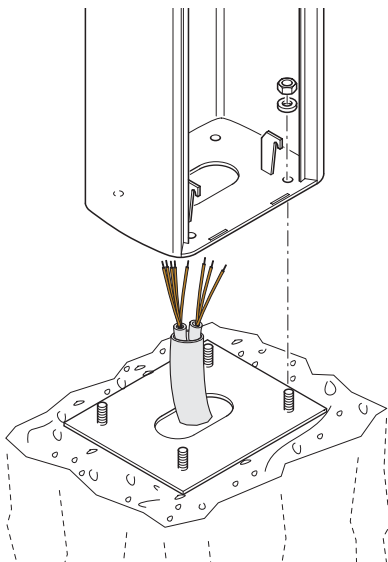
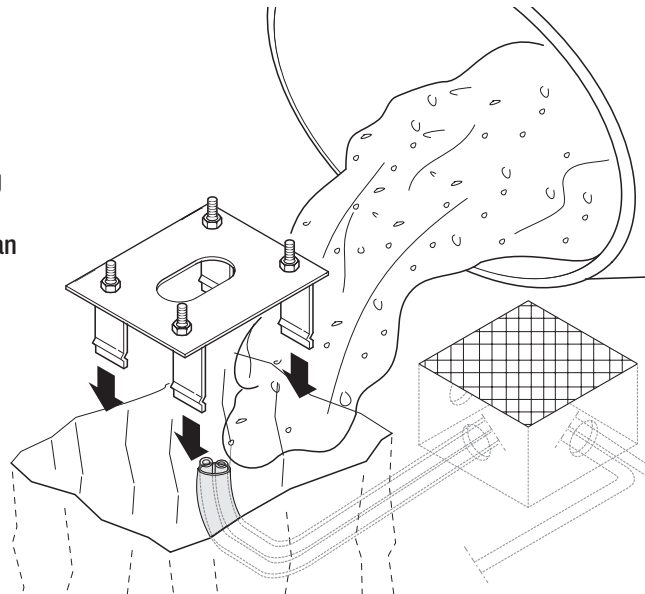

- Remove the nuts and washers from the threaded screws, position the cabinet on the base in correspondence with the 4 threaded screws and secure with the nuts and washers.

**Note:** We recommend installing the cabinet with the inspection hatch facing the internal area.

The data and information provided in this manual are to be considered susceptible to change at any time without warning, by CAME cancelli automatici S.p.A.

## 5.6 Installation of the Unit

- Remove the two screws from the top crown, insert the key into the slot and turn it counter-clockwise.

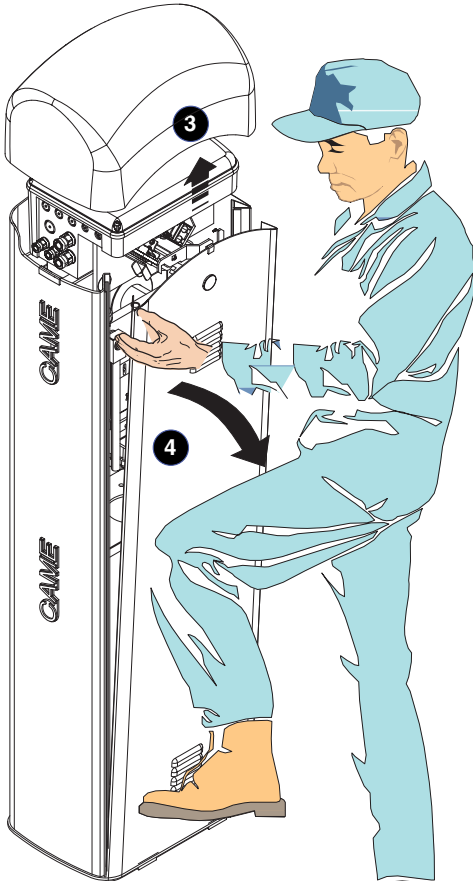
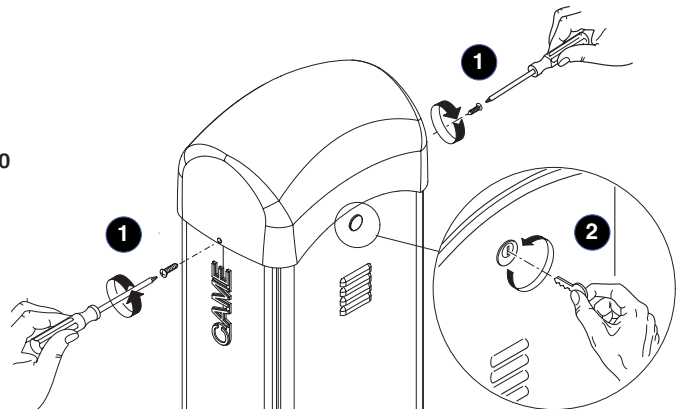

- Lift the top crown and remove the cabinet door.

- The barrier is designed to be installed on the left of the gateway as seen from inside.

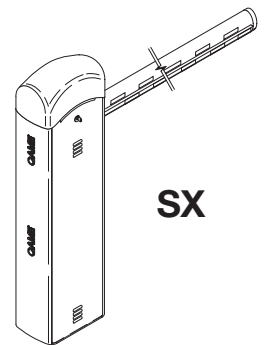

- Should installation on the right be required, the direction of the bar's opening must be inverted. Proceed in the following manner:

- remove the anchor bolt for springs from the transmission arm (1);
- release the gearmotor with the key;
- turn the transmission arm around (2);
- secure the gearmotor again;
- secure the anchor bolt to the transmission arm's opposite hole (3);
- invert the end stop wires on terminals M and N, FA and FC (4).

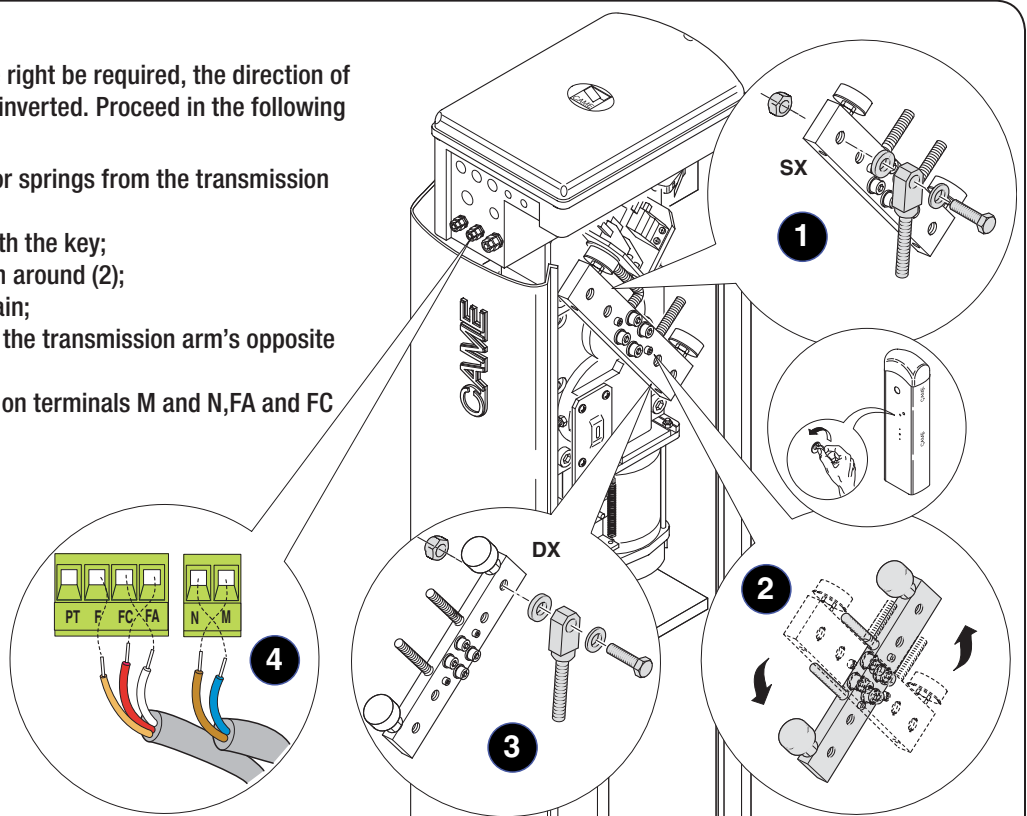
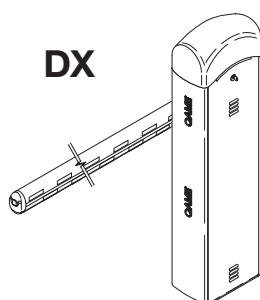

- Position the middle plate between the fitting plate and the bar-fitting cover, and put in one UNI 5931 M8x20 screw without tightening it to facilitate bar assembly.

- Insert the bar in the fitting cover and secure it with UNI 5931 M8x20 and M8x12 screws.

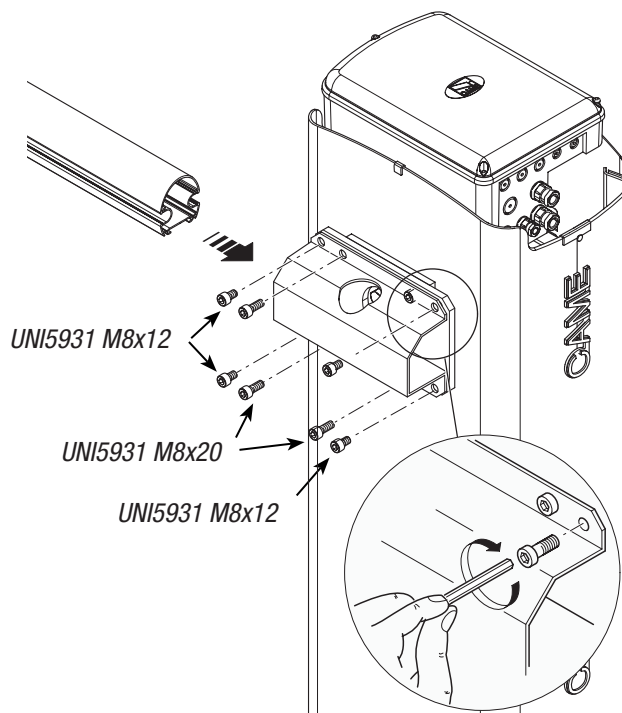
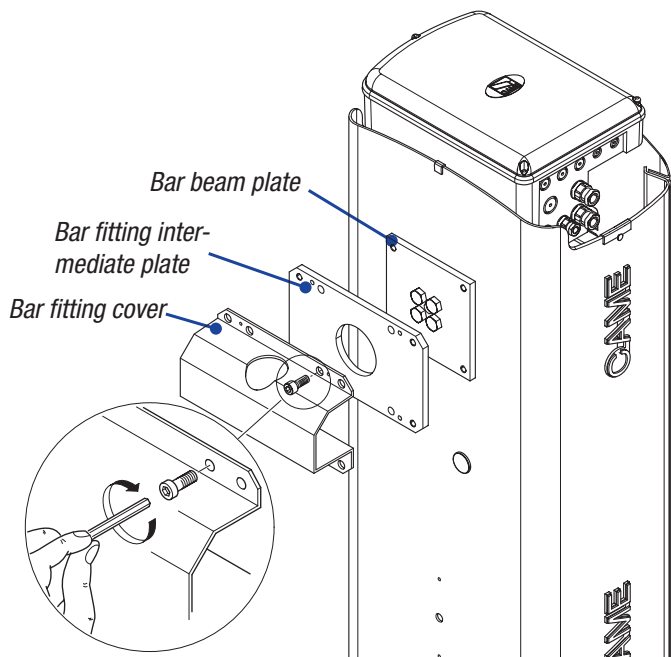

- Measure the length of the bar, cut the bar slot to the same length and insert it in the bar's conduit, a procedure that should be carried out on both sides.

Insert the shock-resistant profile and cut excess length. Lastly, secure the bar end plug with the screws provided.

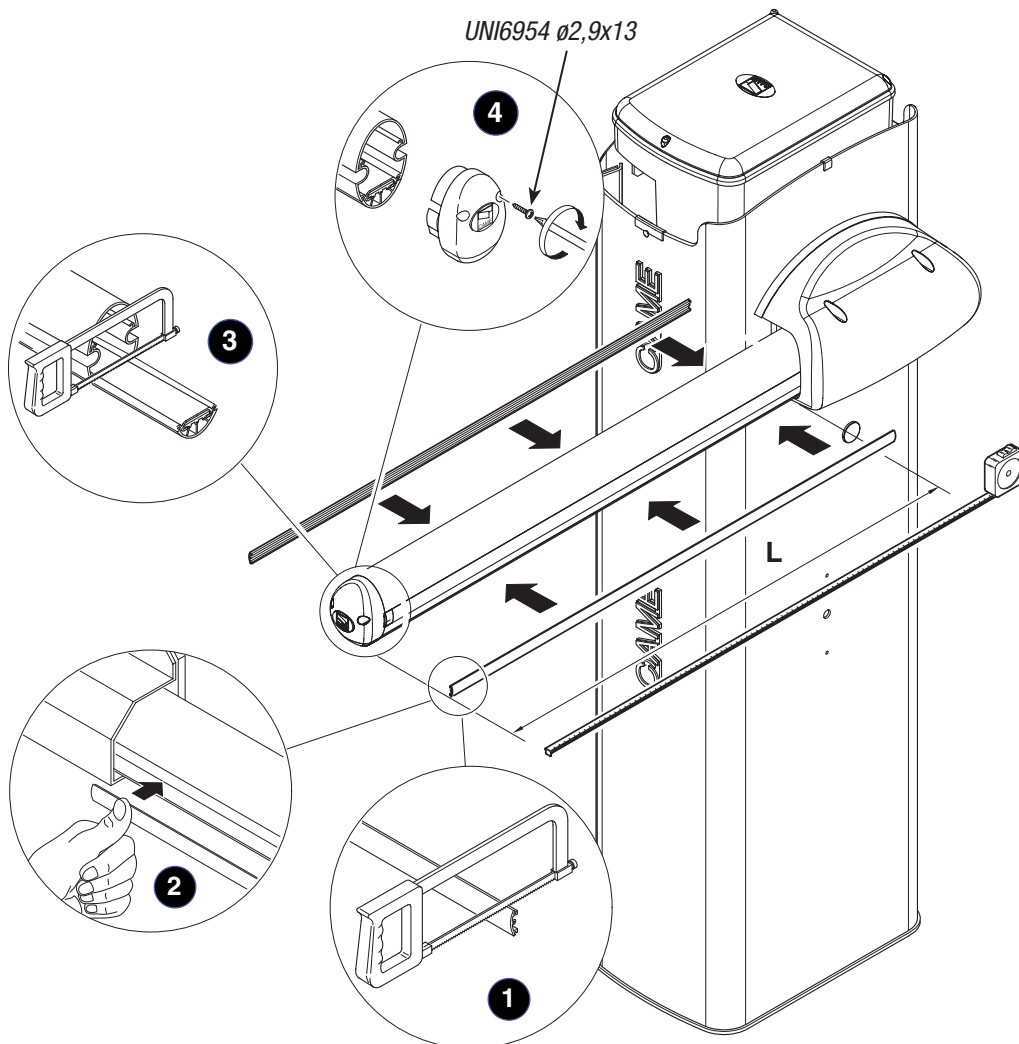



- Tighten the anti-shearing protection cover to the bar fitting with UNI6954 Ø3.9x19 screws.

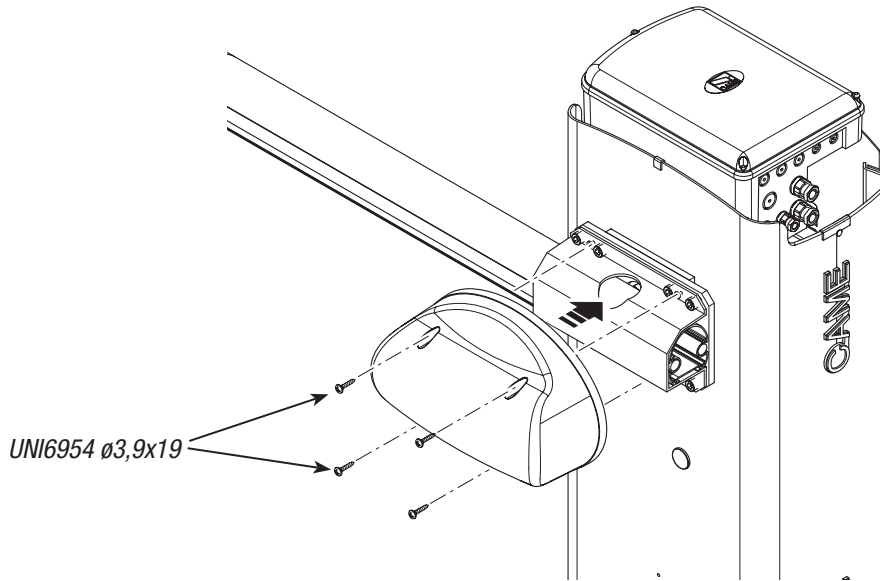

## 5.7 Bar balancing

- Prior to bar balancing, select a suitable spring depending on the situation at hand. See table below:

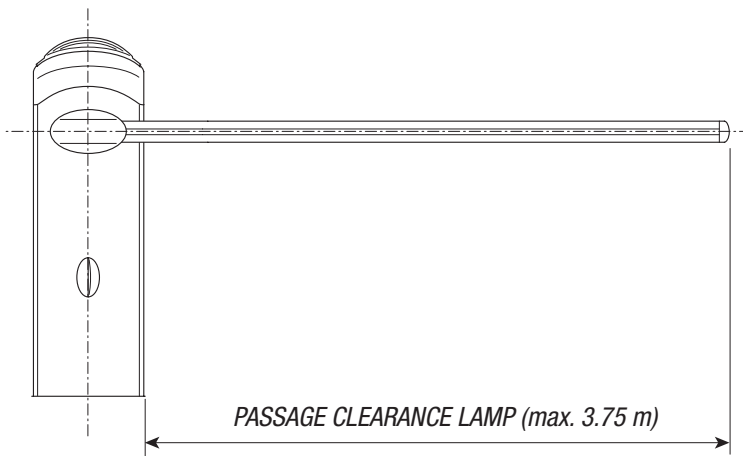

### SPRING TYPES

- spring G02040  $\varnothing_e = 40$  mm
- spring G04060  $\varnothing_e = 50$  mm
- spring G06080  $\varnothing_e = 55$  mm

Passage clearance lamp (m)

	1.5	1.75	2.0	2.25	2.5	2.75	3.0	3.25	3.5	3.75
Bare bar* + shock-resistant profile	Yellow	Yellow	Yellow	Yellow	Yellow	Green	Green	Red	Red	Red
Bare bar* + shock-resistant profile and luminous cord	Yellow	Yellow	Yellow	Green	Green	Green	Green	Red	Red	Red
Bare bar* + rack	Yellow	Green	Green	Green	Green	Red	Red	Red	Red	Red
Bare bar* + luminous cord and rack	Yellow	Green	Green	Green	Green	Red	Red	Red	Red	Red
Bare bar* + shock-resistant profile and mobile barrier support	Yellow	Green	Green	Green	Green	Red	Red	Red	Red	Red
Bare bar* + shock-resistant profile, luminous cord and mobile barrier support	Yellow	Green	Green	Green	Green	Red	Red	Red	Red	Red
Bare bar* + rack and mobile barrier support	Yellow	Green	Green	Green	Green	Red	Red	Red	Red	White
Bare bar* + luminous cord, rack and mobile barrier support	Yellow	Green	Green	Green	Green	Red	Red	Red	Red	White

\* By Bare bar we mean a bar complete with the transparent slot cover and end plug.

- Release the gearmotor and position the bar vertically, and then refasten the gearmotor.

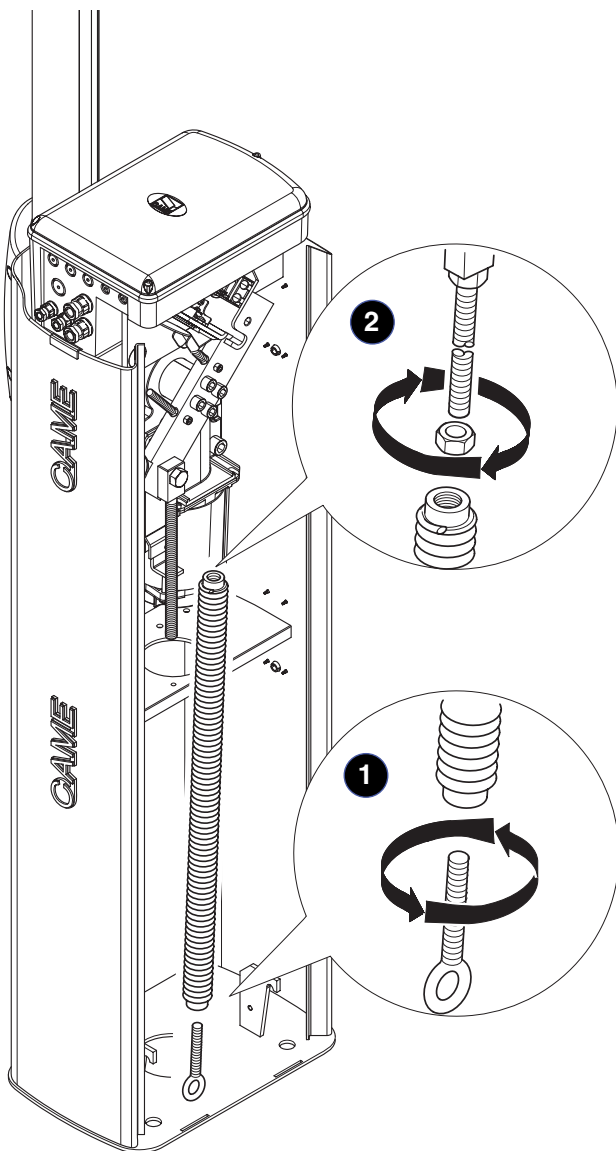

- Tighten the tie rod to the spring and then the top part of the spring to the anchor bolt with an anchor nut.

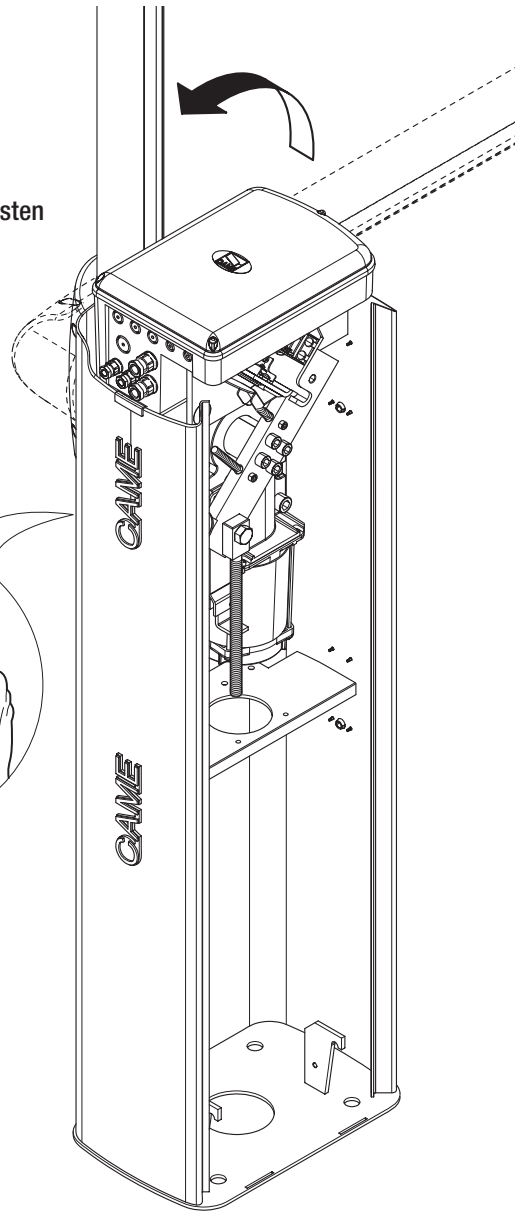

- Hook the tie rod to the anchoring bracket, release the gearmotor and manually turn the spring to increase or decrease traction until the bar rests at 45°.

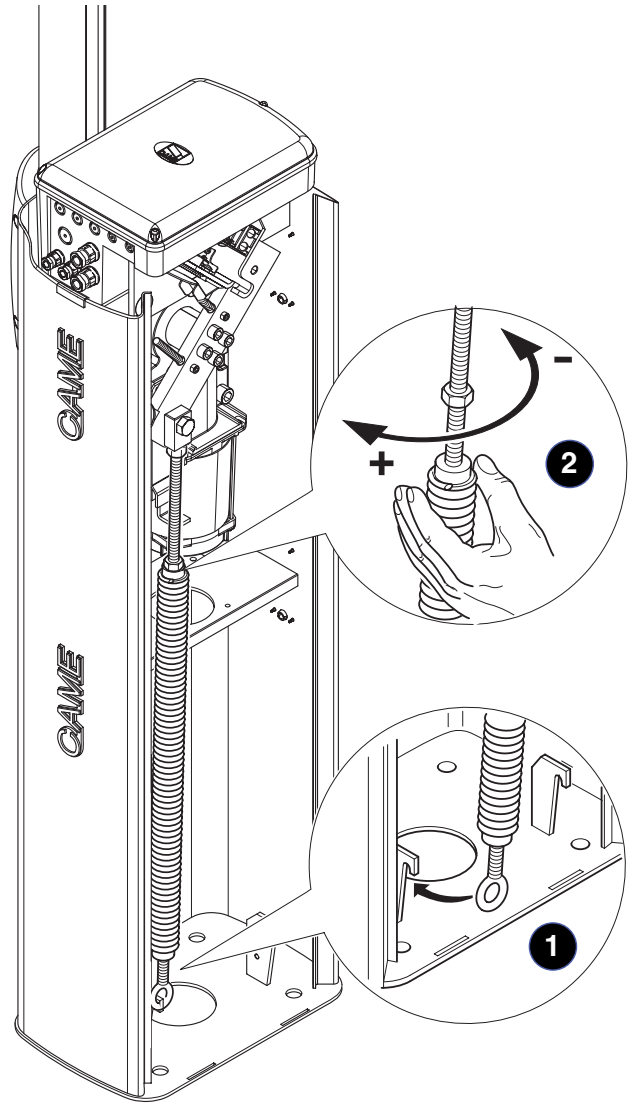
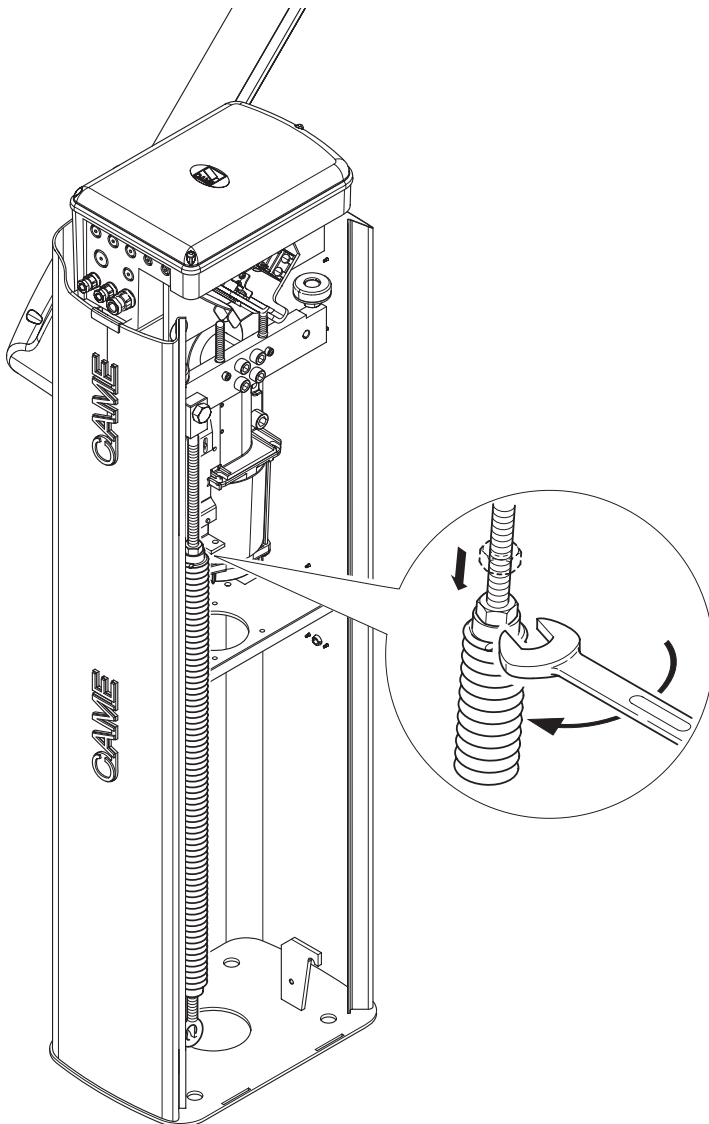
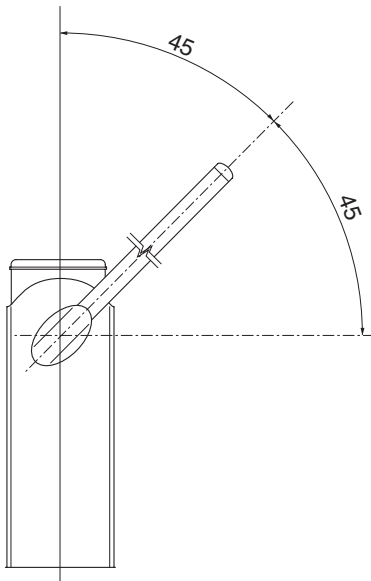

- Tighten the blocking nut and refasten the gearmotor.
- Note: make sure the spring functions properly:
  - the spring is loose when the bar is in the vertical position (at rest)
  - the spring is tight when the bar is in the horizontal position (tense).
- Perform any electrical connections to the control panel (see electrical connections paragraph).

## 5.8 End stop adjustment

N.B.: perform this procedure after finishing the electrical connections.

Close the door and power up the system, activate the barrier to make sure it is parallel with the closed and at about  $89^\circ$  when open.

**⚠ Warning!** For greater safety and better unit performance, the bar's opening and closing operations should be carried out with the inspection hatch closed!

If any adjustment of the vertical position (= opening) is needed, open the inspection door and rotate the free damper clockwise (to increase the bar's run) or counter-clockwise (to decrease the run).

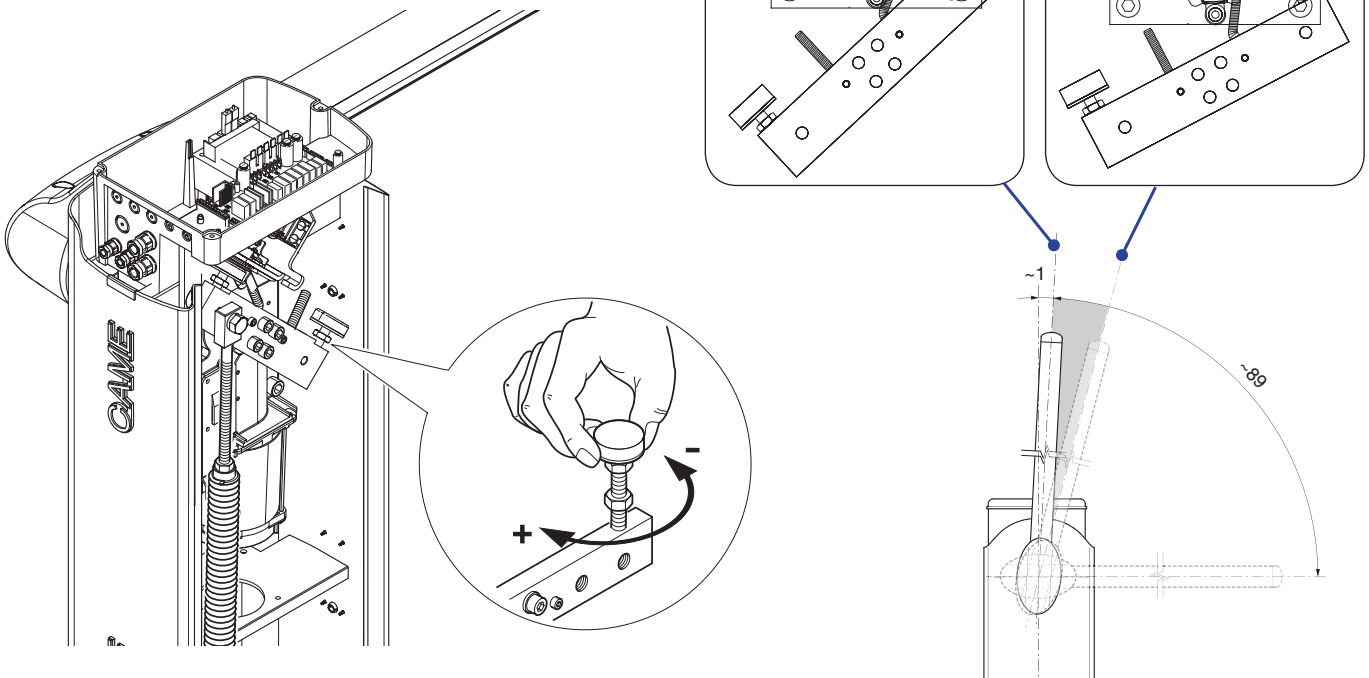

Similarly, open the bar and adjust the free damper, to regulate the horizontal position (= closing).

**⚠ Warning!** The bar's stop position is preceded by the slowing phase by means of a tab and spring system that activates the slowing-down microswitch prior to the bar's total stop.

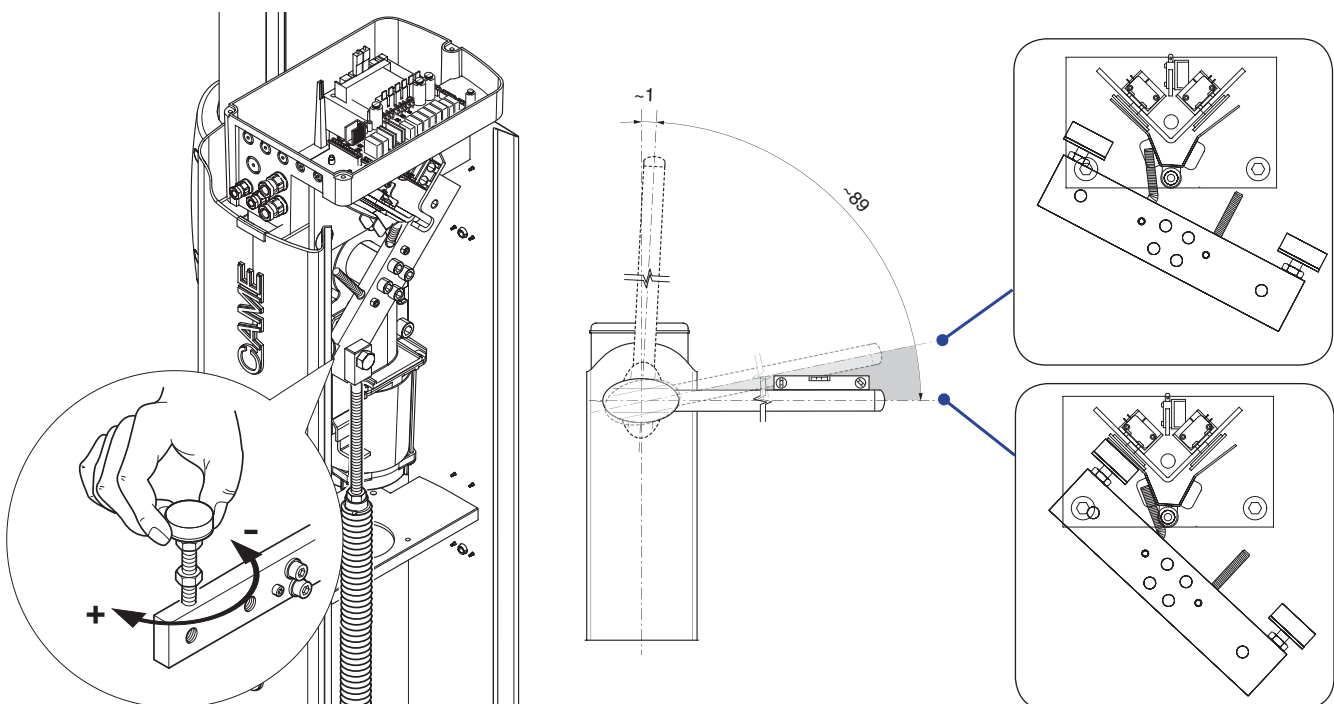

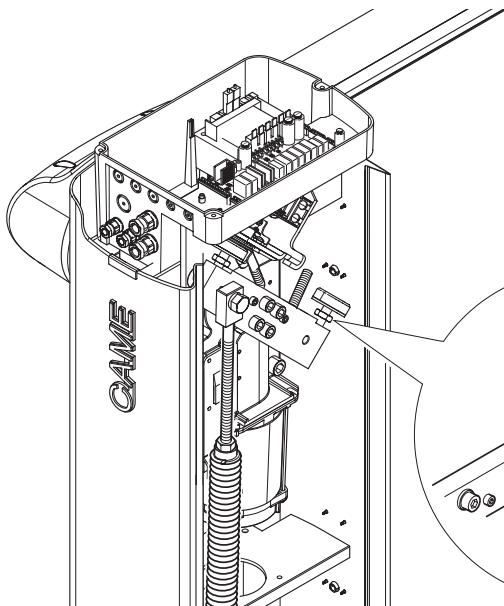

- After bar opening and closing adjustment, tighten the locking nuts under the dampers.

- Once you have completed all mechanical and electronic installation procedures, secure the control panel cover,...

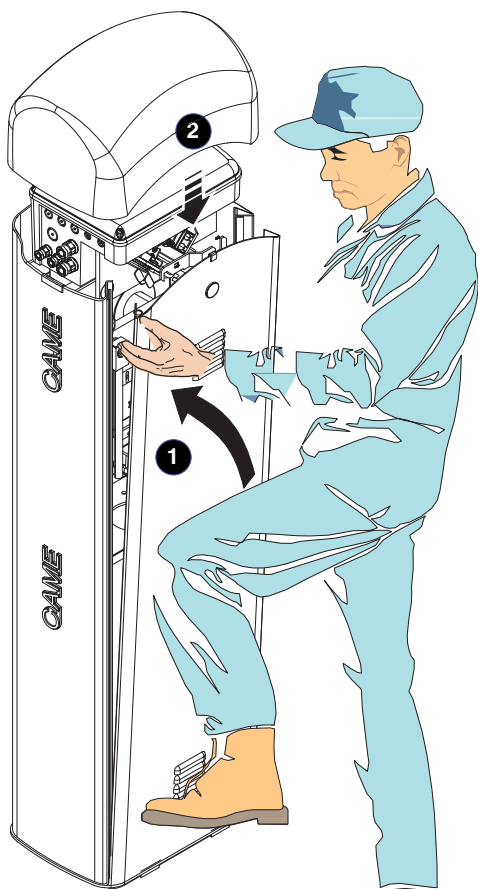
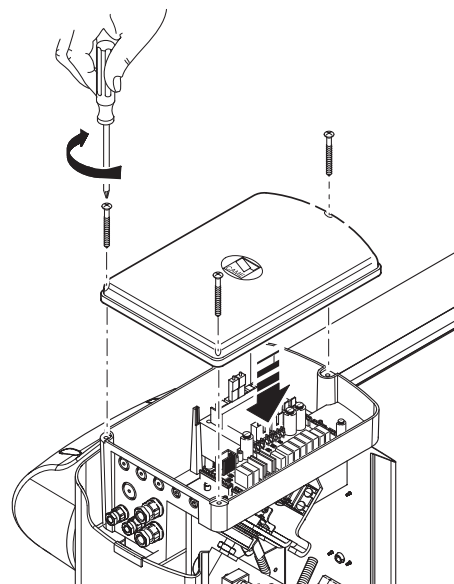

- ...reposition the inspection door and top crown.

- Turn the key clock wise and lock the protective top cap using the  $\varnothing 3,9 \times 13$  supplied with the package.

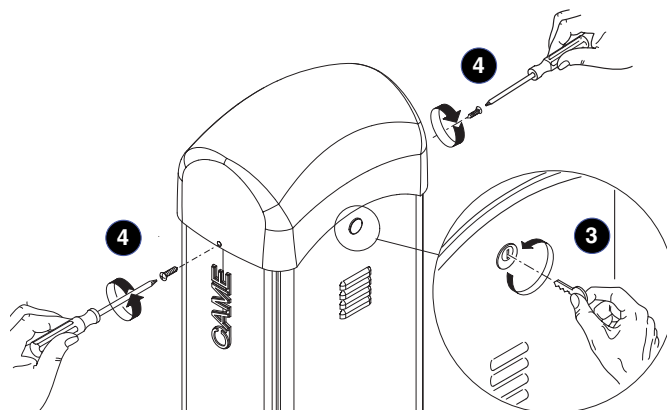

## 5.9 Manual release of the barrier

- Insert the key into the lock and turn it clockwise. Manually raise the bar and block it again by turning the key counter-clockwise.



**WARNING!** The release procedure may constitute a hazard for the user when, for whatever reason – the bar is fixed improperly to the housing during assembly, or the bar is cracked or broken in an accident, and so on – the tension springs no longer provide balance! These can thus cause a **brusque rotation of the bar attachment and/or of the bar itself.**

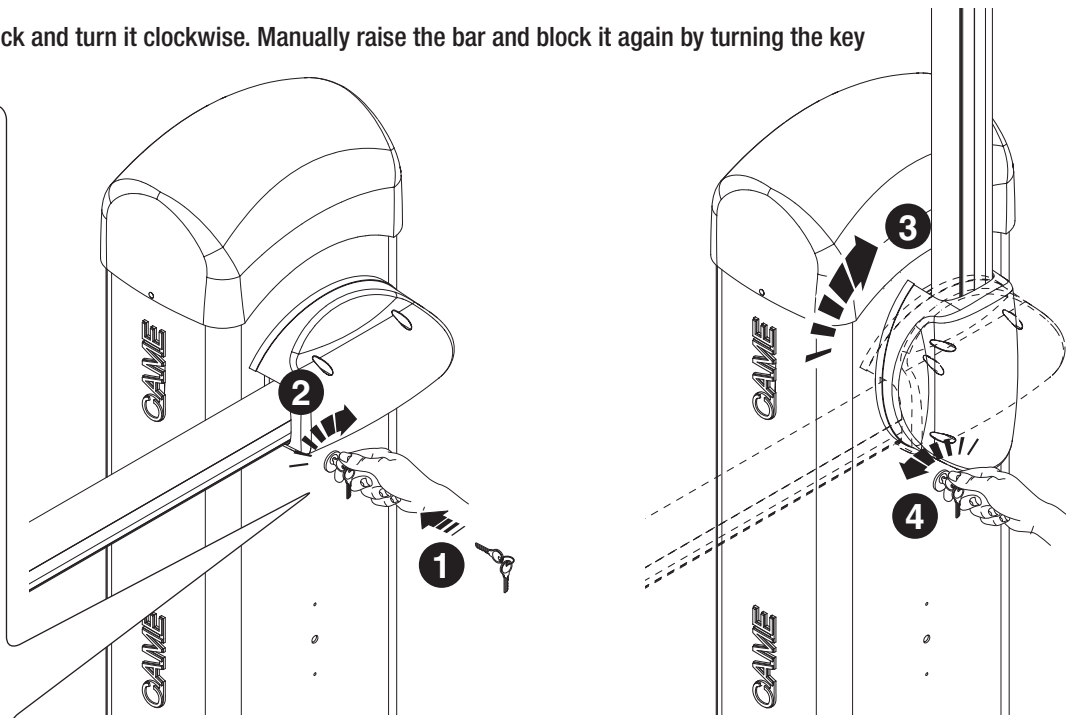

## 6 Description control panel

This product is engineered and manufactured by CAME cancelli automatici s.p.a. and complies with current safety regulations. Guaranteed 24 months if not tampered with.

The control panel works on 230V a.c. of power, 50/60Hz frequency.

Both command and control devices and accessories are 24V powered. **Warning!** Accessories must not exceed 40 W overall.

The control unit is fitted with an amperometric device which constantly regulates the motor's drive coefficient.

When the bar runs into an obstacle, the amperometric sensor immediately detects an overcharge in the drive and redirects the gate's direction of movement, and:

- during opening: the bar stops;
- during closing: the bar reverses its direction until it opens completely; automatic closure is thus activated.

**Caution!** after three consecutive direction reversals, the bar will remain up and automatic closure will be discontinued. To close the gate, use the radio remote control or the push-button.

All connections are protected by quick fuses, see table.

The card provides and controls the following functions:

- automatic closing after an open-command;
- immediate closure;
- pre-flashing by the motion indicator;
- obstacle detection when gate is still in any position;
- slave function;
- function that increases the braking action of the barrier.

The following command modes are possible:

- open/close;
- open/close and maintained action;
- open;
- complete stop.

Apposite trimmers regulate:

- the automatic closing run time;
- the amperometric device's detection sensitivity;

Optional accessories:

- Flashing Crown and Luminous band.
- bar open light marks the position of opening of the bar; it turns off after the closing operation;
- LB38 Card, provides power supply through a battery, in case of a power outage. When power comes back on, it also recharges the batteries (see relative technical literature).

**Warning!** Before acting on the machinery, cut off the main power supply and disconnect any emergency batteries.

TECHNICAL FEATURES	
Power supply	230V - 50/60Hz
max. rated power	400W
Power draw when idling	25W
Max power of 24V accessories	40W
Insulation rating	II
Material	ABS

FUSES	
protection:	fuse type:
Motor/s	10A-F
Electronic board (power supply line)	3.15A-F
Accessories	2A-F
Control devices	630mA-F

The data and information provided in this manual are to be considered susceptible to change at any time without warning, by CAME cancelli automatici S.p.A.

## 6.1 Main components

- 1 - Accessories fuse
- 2 - Line fuse
- 3 - Control unit fuse
- 4 - Motor fuse
- 5 - Accessories terminals
- 6 - Radio-frequency card input (see table page 19)
- 7 - SENS Trimmer: adjusts amperometric sensitivity
- 8 - TCA Trimmer: adjusts automatic closing time
- 9 - "Function selector" Dip switch
- 10 - Code storing button
- 11 - Signalling LEDs for radio codes/automatic closing
- 12 - Adjustment connectors for deceleration speed
- 13 - Connectors for LB38 battery charger
- 14 - Command-type selection jumper for button 2-7
- 15 - Transformer
- 16 - Power supply Terminals
- 17 - Motor Terminals
- 18 - Endstop Terminals

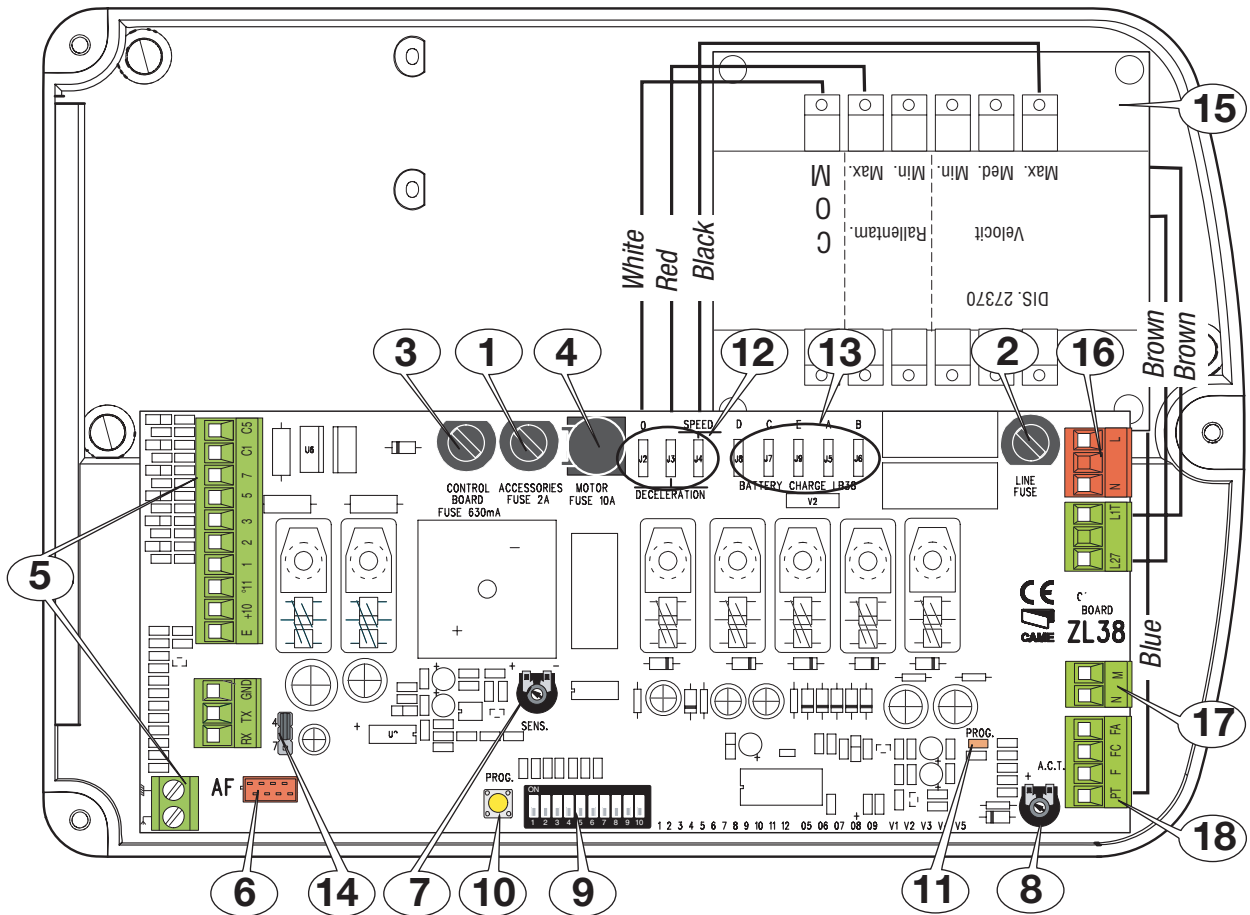

## 6.2 Electrical connections

### Gearmotor, endstop

Description of required electrical connections. When installing on the right side, see page 7.

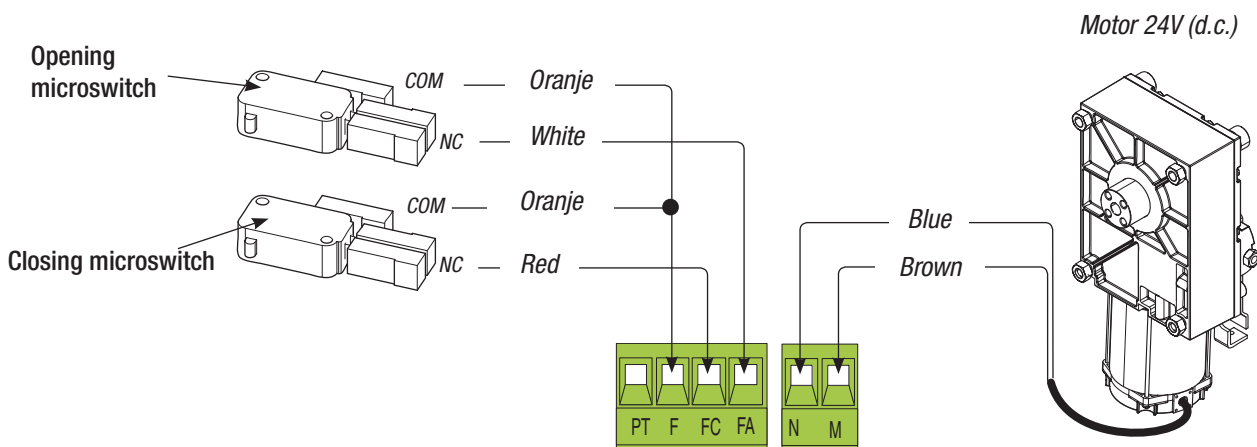

Power supply to accessories

Terminals for powering the following accessories:

- 24V a.c. (normally alternated power);
  - 24V a.c. (continuous power) when the emergency batteries are in operation;
- Overall power allowed: 40W

Power supply 230V (a.c.) 50/60 Hz

Cable lug with bolt and washer for connecting to earth

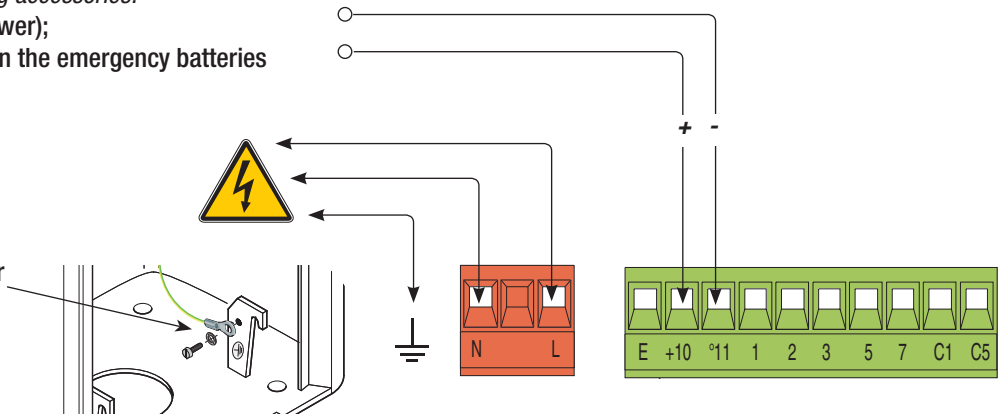

Command devices

**Pulsante Stop button (N.C. socket)** - Bar stop button. Excludes automatic closing. For motion to resume, press the command button or the remote control button.

Se non viene utilizzato, posizionare il dip 9 in ON.

**Opening button (N.O. contact)** - Bar opening command.

**Command button (N.O. contact)** - Bar opening or closing button. By pressing on the button, the bar opens or inverts its movement depending on the selection made on Dipswitch 2. Check setting of the Jumper (n. 14, page 15), as per figure.

**Closing button (N.O. contact)** - Bar closing command. Obligatory in the event of "maintained action" function. Set jumper according to figure.

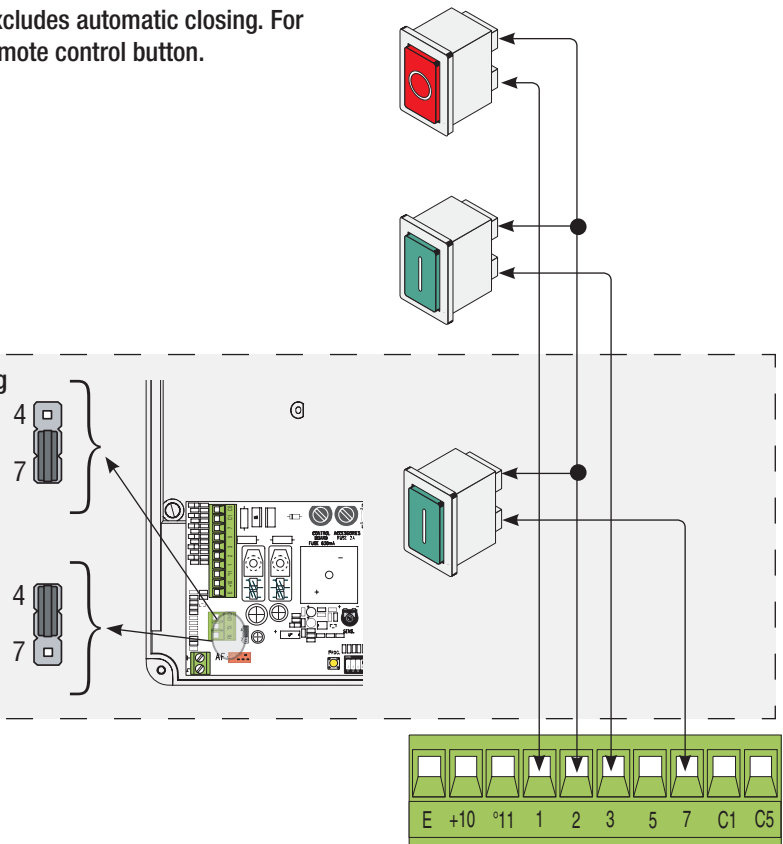

**(N.O.)Contact for "immediate closing"**  
Automatic bar closing after an obstacle comes within the range of the safety devices.  
If unused, set Dipswitch 8 to ON.

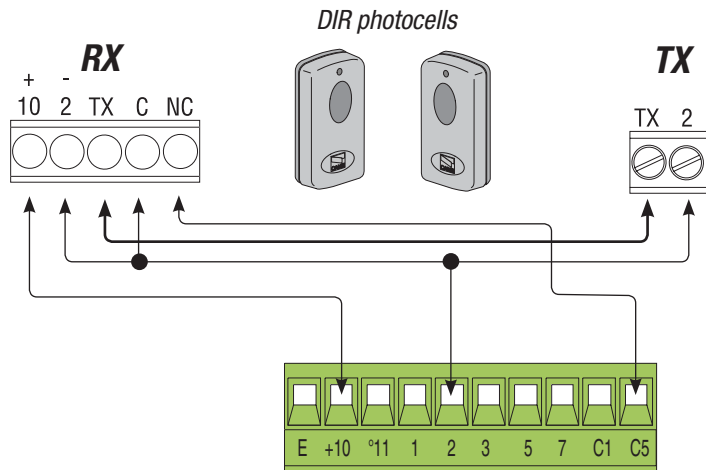

The data and information provided in this manual are to be considered susceptible to change at any time without warning, by CAME cancelli automatici S.p.A.



Warning devices

Flashing Crown and/or Luminous band (Contact rating: 24V - 32W max.) - Flashes when bar is opening and closing.

Open barrier warning light (contact rating: 24V - 3W max.) - Signals when bar is in 'up' position, turns off once bar is down.

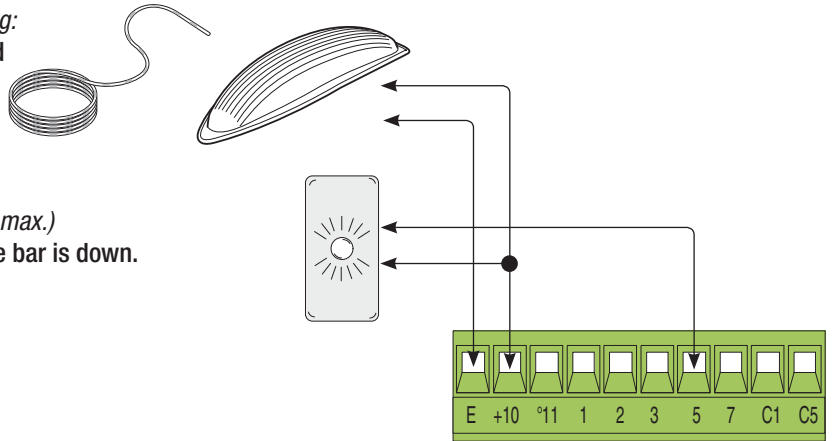

Safety devices

**(N.C.) contact for «re-open during closing phase»**  
 - Input for safety devices such as photocells, sensitive edges and other EN 12978 compliant devices. When bar leaves are closing, opening the contact causes reversal until total opening is obtained.

**If not used, short circuit contact 2-C1.**

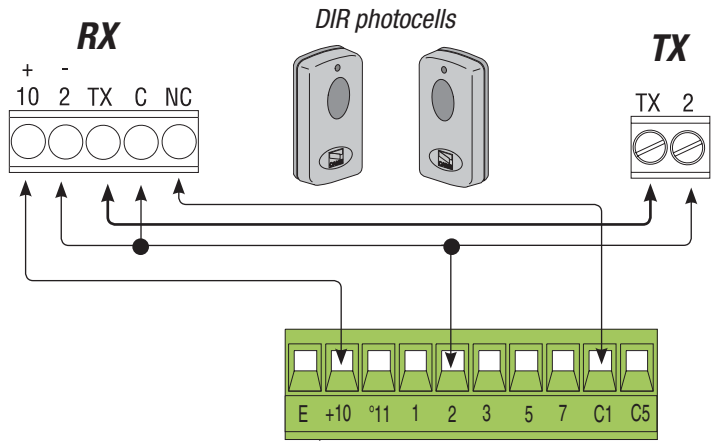

6.3 Adjusting movement and deceleration speeds

To adjust the opening and closing speed, move transformer faston, labeled "A" to Min = minimum, Med = medium or Max = maximum, while, for decelerations move the faston "B" to Min. or Max..

Max opening or closing speed; Max decelerations.

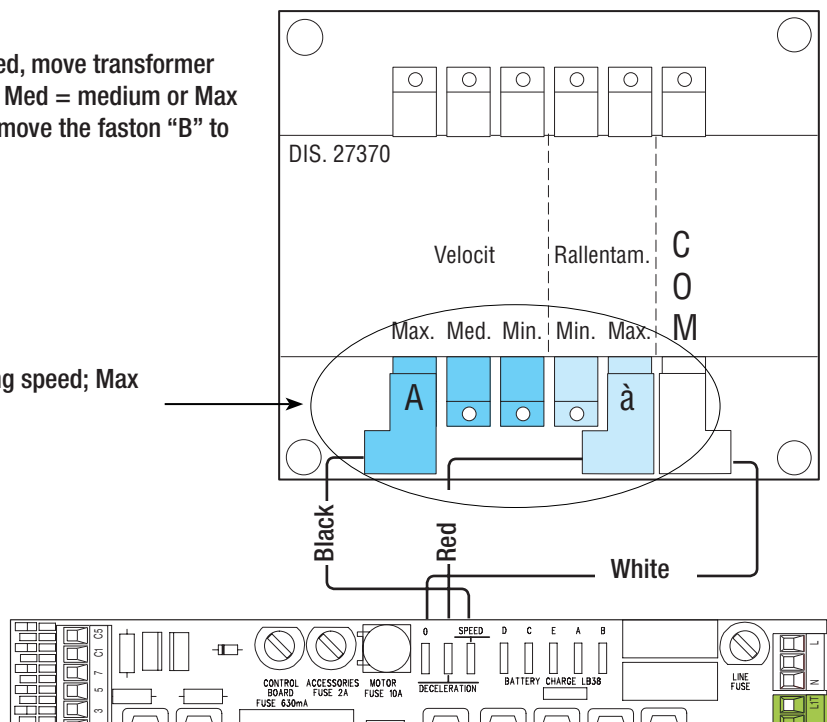

The data and information provided in this manual are to be considered susceptible to change at any time without warning, by CAME cancelli automatici S.p.A.

## 6.4 Selecting functions

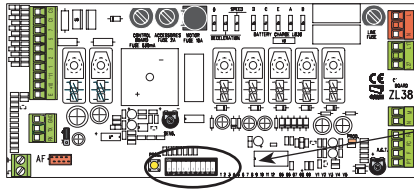

Default setting



- 1 ON - **Automatic closing** - the automatic closing timer is activated when on opening the bar leaf has reached the full open stroke. The time is preset and adjustable, and is subject to the action of any safety devices. It does not activate after a total safety "stop" or during a power outage (1 OFF - deactivated);
- 2 OFF - **"Open-close"** function with button [2-7] and remote control (with built-in radiofrequency card).
- 2 ON - **"Open only"** function with remote control (featuring built-in radiofrequency card).
- 3 ON - 24V power output on contact (10-E) bar in motion and in open position;
- 3 OFF- 24V power output on contact (E-10) bar in motion;
- 4 ON - **Maintained action** - the bar works by keeping the button pressed (one button [2-3] for opening, and one button [2-7] for closing) (Set jumper n°14 according to figure pag. 16).
- 5 ON - **Pre-Opening and closing flasher** - Following and opening and closing command, the flasher connected to [10-E], flashes for 5 seconds before motion begins.
- 6 ON - **Obstacle detected** - When motor is stopped (bar closed or after a total stop command) it prevents any movement if safety devices, such as photocells, detect any obstacles.
- 7 ON - **"Slave" function** - Activate when two barriers are coupled (see connecting two coupled barriers paragraph);
- 8 OFF - **Immediate bar closing** - Immediately closes bar when obstacle comes within the range of the safety devices. Insert safety device on [2-C5]; if unused set Dipswitch to ON.
- 9 OFF - **Total stop** - This function stops the bar and then excludes any automatic closing cycle; to set in motion again, use either the keypad or transmitter. Insert the safety device in [1-2]; If unused, set DIP switch to ON.
- 10 ON - **Brake Action** - increases braking action on the bar when closing (10 OFF – deactivated)

## 6.5 Adjustments

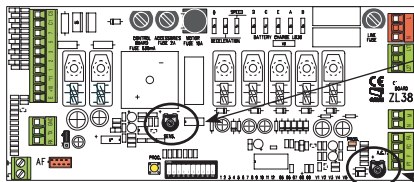

SENS.



A.C.T.

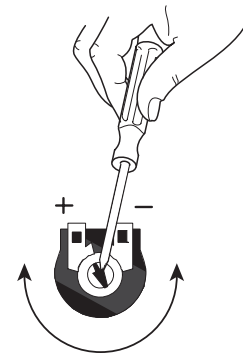

### ELENCO TRIMMER DI REGOLAZIONI:

- «**A.C.T.**» Sets the waiting time while open. Once this time has elapsed, closing automatically takes place. The waiting time may be set from 1 to 120 seconds.
- «**SENS**» Sets the amperometric sensitivity that controls the force generated by the motor during movement; if the force exceeds the set level, the system intervenes by inverting the direction of motion.

## 7 Activating the remote control

### Antenna

Connect the antenna's RG58 cable to the opposite terminals.

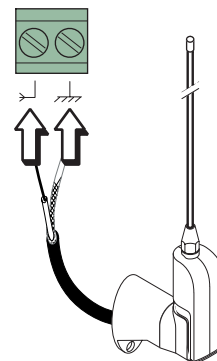

### Radiofrequency card

Lock the radiofrequency card into the electronic card AFTER CUTTING OFF THE POWER SUPPLY (or after disconnecting the batteries).

N.B.: the electronic card only recognises the radiofrequency card when the power is on.

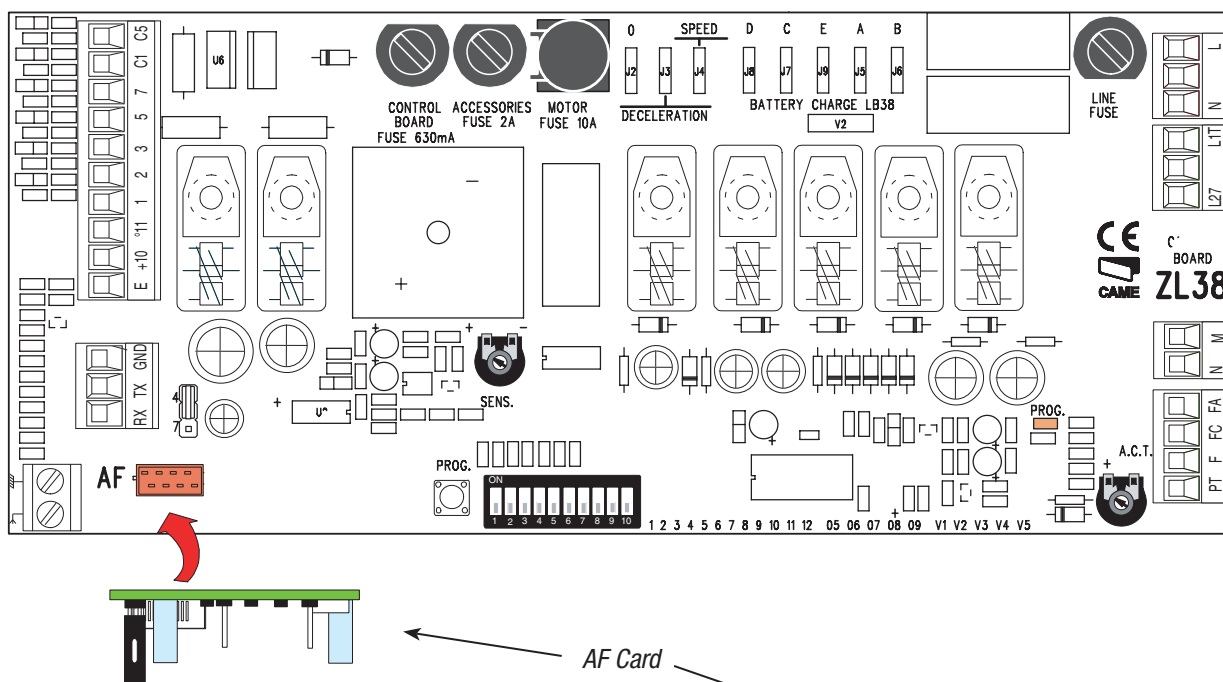

Frequency/MHz	radiofrequency card	Series of transmitters
FM 26.995	AF130	TFM
FM 30.900	AF150	TFM
AM 26.995	AF26	TOP
AM 30.900	AF30	TOP
AM 433.92	AF43S / AF43SM	TAM / TOP
AM 433.92	AF43SR	ATOMO
AM 40.685	AF40	TOUCH

### Transmitters

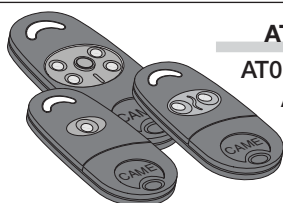

**ATOMO**  
AT01 • AT02  
AT04

See instructions attached to AF43SR radiofrequency card

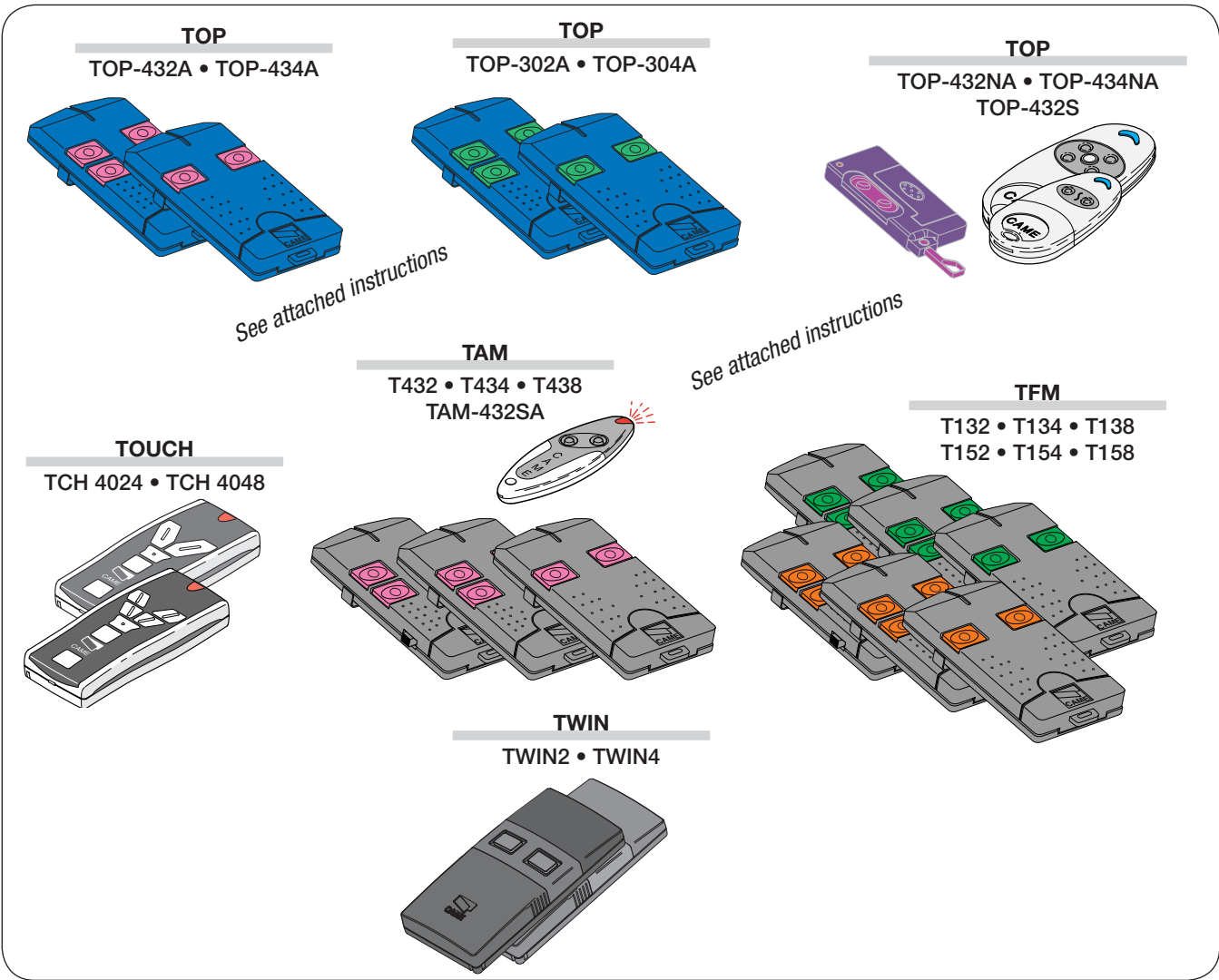

See attached instructions

See attached instructions

**Memorisation**

- Keep pressed the **PROG** button on the electronic card. The LED will flash.

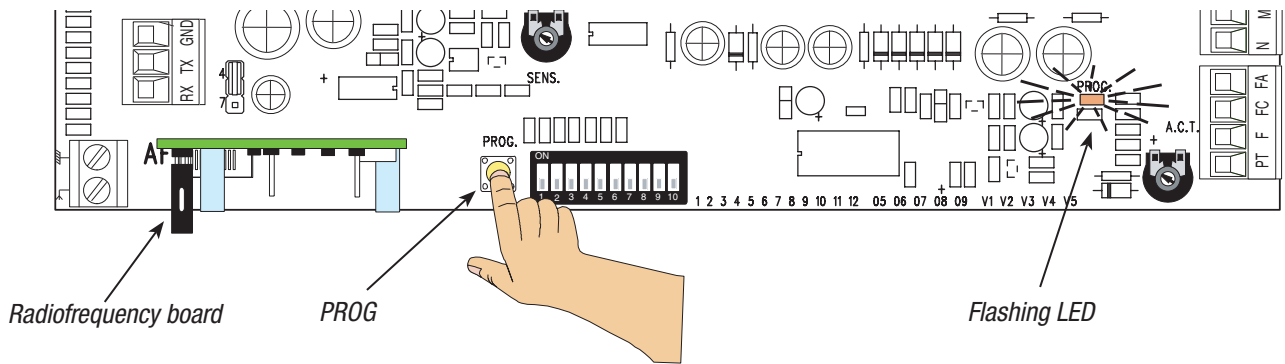

- Press the button of transmitter to memorise. The LED will stay on to signal memorisation.

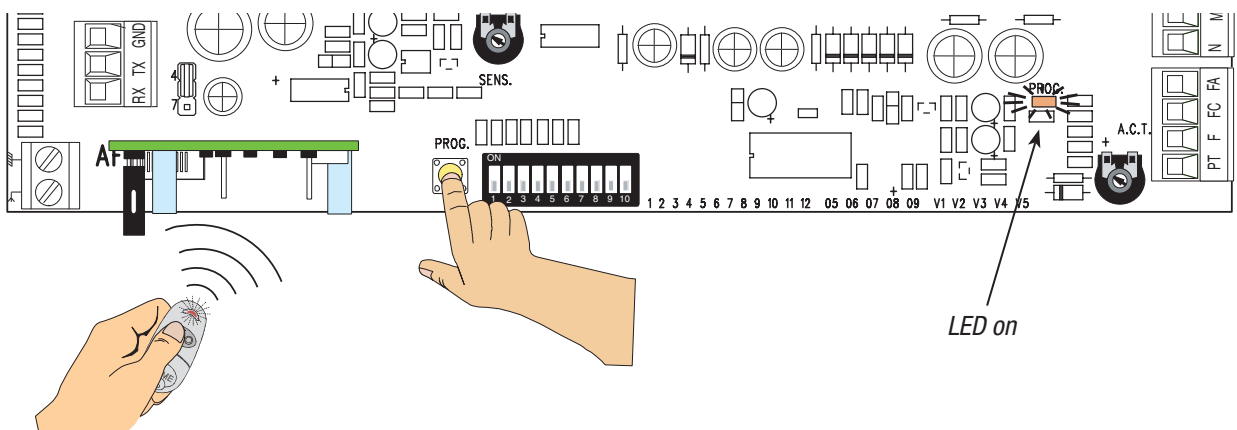

The data and information provided in this manual are to be considered susceptible to change at any time without warning, by CAME cancelli automatici S.p.A.

## 8 Connecting two coupled barriers to one command

SX

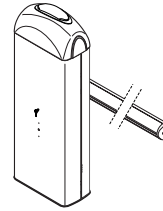

DX

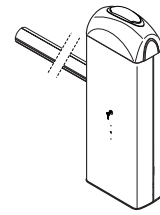

- Determine the Master and Slave barrier.

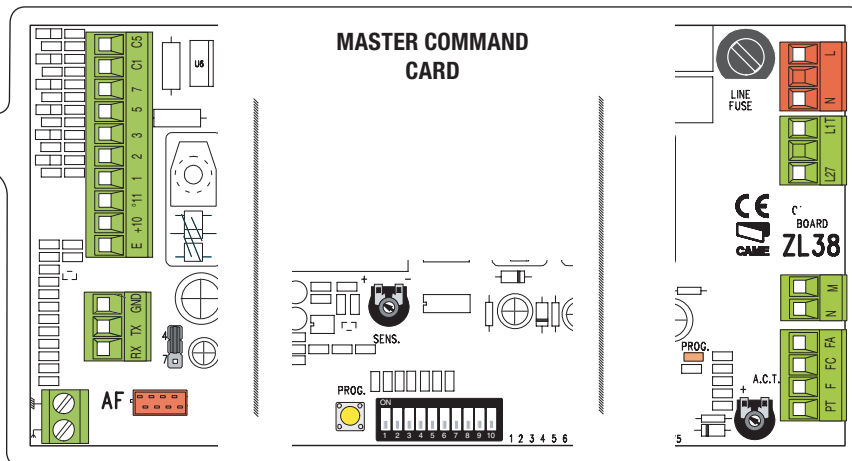
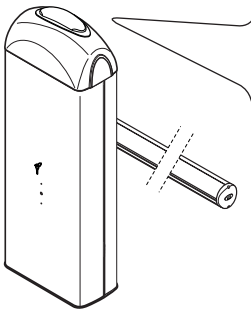

- On the pre-chosen Master command card, perform all the connections (see electrical connections paragraph)

the installation procedure for the remote control, settings and adjustments.

- on the pre-chosen Slave command card, set Dipswitch 7 to ON, perform power connection on terminal L-N, connect the device to 10-E terminal output, adjust to the same speed and deceleration as for the Master barrier.

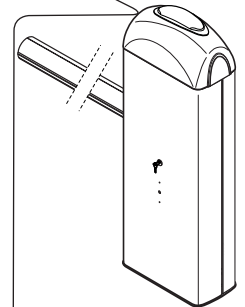
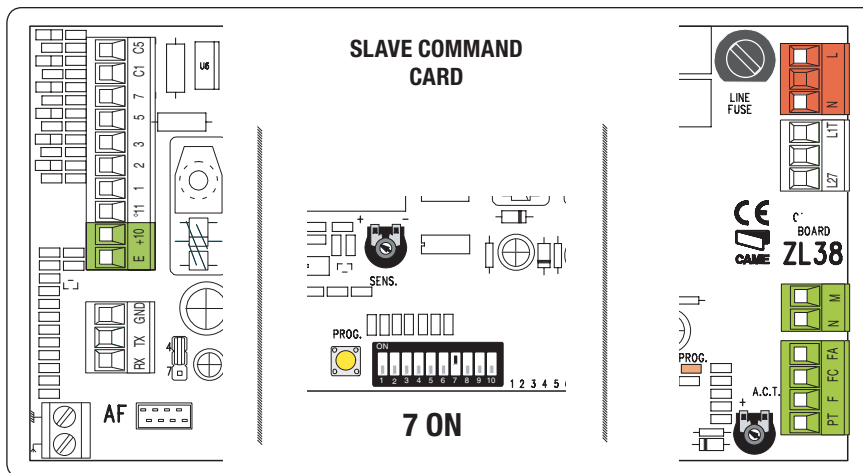

- Perform connection between two command cards through RX-TX GND terminals.

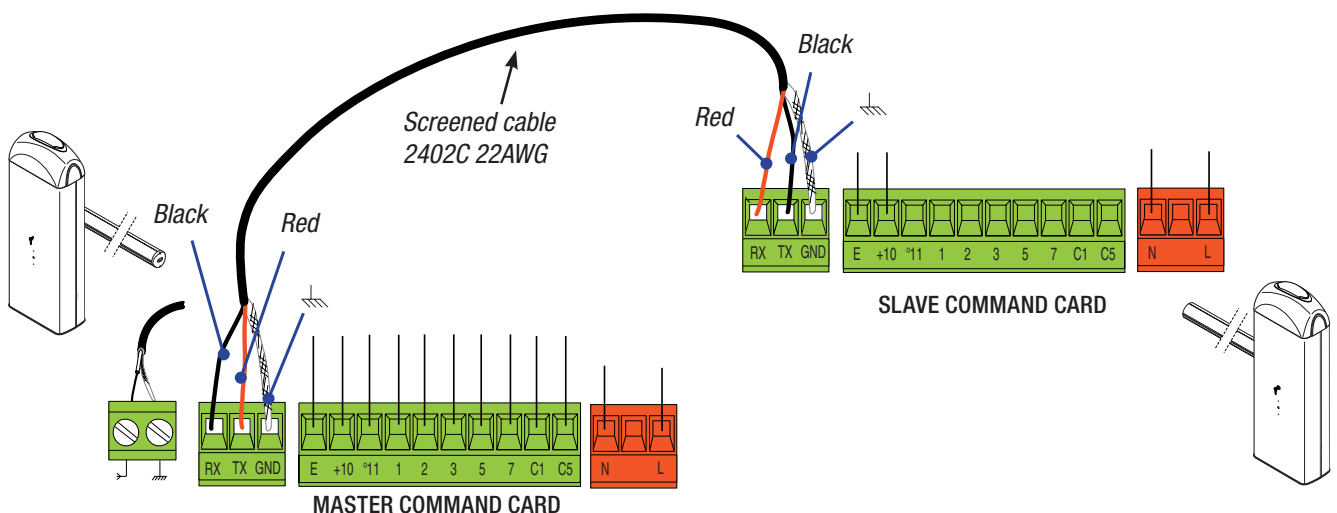

## 9 Safety instructions

### **Important safety instructions**

This product must only be employed for its originally intended use. Any other use is wrong and potentially dangerous. The manufacturer cannot be held liable for any damages resulting from wrongful, erroneous or negligent uses.

Avoid using near mechanical moving parts. Stay out of the opening/closing arc when operator is in motion.

Do not exercise force against the motion of the operator as this could result in potentially dangerous situations.

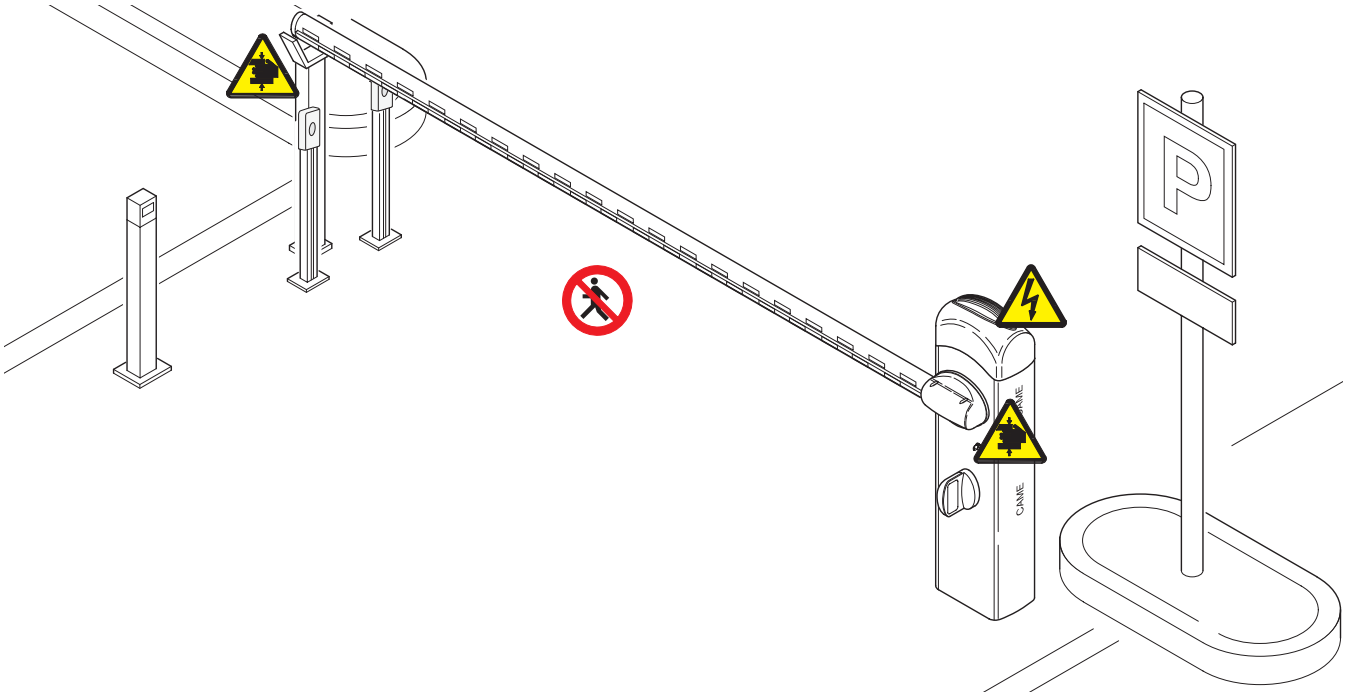

Do not allow children to play or loiter within the opening/closing arc of the operator. Keep remote controls and any other command device out the reach of children, to prevent operator from being activated by accident.

In the event of anomalous behaviour, stop using the operator immediately.



Danger of crushing hands



Danger! High voltage



No transit during operation

## 10 Maintenance

### 10.1 Periodic maintenance

 Periodic maintenance to be carried out by the end-user is as follows: wipe clean the glass surface of the photocells; check that the safety devices work properly; remove any obstruction.

We suggest checking the state of lubrication and tightness of the anchoring screws on the operator.

-To check the efficiency of the safety devices, move an object in front of the photocells when gate is closing. If the operator inverts the motion or stops, the photocells are working properly.

This is the only maintenance procedure to be carried out with the power source connected.

-Before performing any maintenance procedures, cut off the main power, to prevent possible accidents due to bar movement.

-To clean the photocells use a water dampened cloth. Do not use solvents or other chemical products which may ruin the devices.

-Make sure there are no plants within the photocell's beam, and that the bar motion is free of any obstacles.

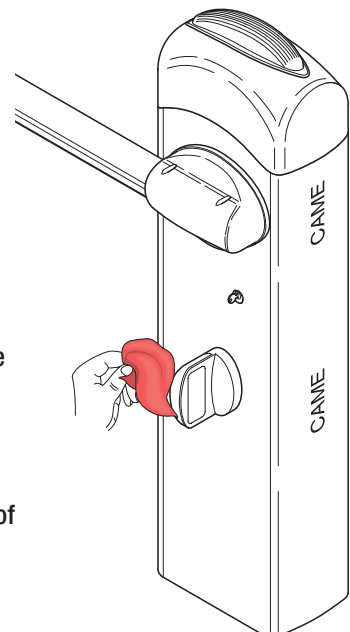

**Periodic maintenance log for end-user (every 6 months)**

Date	Notes	Signature

**10.2 Extra-ordinary maintenance**



The following table serves to note down any extraordinary maintenance, repairs or improvements performed by specialised firms.

N.B.: Any extraordinary maintenance must be performed by specialised technicians.

**Extra-ordinary maintenance log**

Installer's stamp	Operator name
	Date of job
	Technician's signature
	Requester's signature
Job performed _____ _____	

Installer's stamp	Operator name
	Date of job
	Technician's signature
	Requester's signature
Job performed _____ _____	

Installer's stamp	Operator name
	Date of job
	Technician's signature
	Requester's signature
Job performed _____ _____	

Installer's stamp	Operator name
	Date of job
	Technician's signature
	Requester's signature
Job performed _____ _____	

Installer's stamp	Operator name
	Date of job
	Technician's signature
	Requester's signature
Job performed _____ _____	

### 10.3 Problem solving

*La risoluzione dei problemi è a cura dell'installatore professionale o a persona competente.*

MALFUNCTIONS	REFERENCES	CHECKS
The unit neither opens nor shuts	1-2-3-4-6-8-18	1 – Close the inspection hatch with the key and check the release lock
The unit opens but does not close	4-7-10	2 - Disable “steady movement” with dipswitch
The unit shuts but does not open	4-7-9	3 – Check power supply and fuses
No automatic closure	11-12-13	4 - N.C. safety contacts open (1-2 / 2-C1 / 2-C5)
The unit does not work if the remote control is used	2-14-16	6 - Disable master-slave function
The unit inverts direction	7-18	7 – Check spring tension and balancing
The unit works only with remote control	22	8 – Disable obstacle detection with dipswitch
The photoelectric cell does not react	12-23-24	9 – Check if end stop opens
The signalling LED indicator flashes rapidly	4	10 – Check if end stop closes
The signalling LED indicator remains on	13	11 - Activate “automatic closure” dip switch
The unit does not end its run	7	12 – Check the correct direction of movement
The bar is not properly balanced	7-15	13 - (2-3 / 2-4 / 2-7) command button
The unit does not slow down	7-15	14 –Check jumper on AF43S, turn on/off power
The unit does not work with the back-up batteries	8-25-26	15 – Check the bar length ratio with mountable accessories
The unit is slow to respond	7	16 – Re-save radio code
		18 – Adjust sensitivity
		22 - Enter or duplicate the same code in all the remote controls
		23 – Activate the photoelectric cell with the dipswitch
		24 – Connect the photoelectric cells in a series, not in parallel
		25 – Dead batteries
		26 –Respect the photoelectric cells' polarity



## 11 Demolition and disposal

 In its premises, CAME CANCELLI AUTOMATICI S.p.A. implements an Environmental Management System certified in compliance with the UNI EN ISO 14001 standard to ensure environmental protection.

Please continue our efforts to protect the environment—which CAME considers one of the cardinal elements in the development of its operational and market strategies—simply by observing brief recommendations as regards disposal:

 **DISPOSAL OF PACKAGING** – The packaging components (cardboard, plastic, etc.) are all classifiable as solid urban waste products and may be disposed of easily, keeping in mind recycling possibilities.

Prior to disposal, it is always advisable to check specific regulations in force in the place of installation.

**PLEASE DISPOSE OF PROPERLY!**

 **PRODUCT DISPOSAL** – Our products are made up of various types of materials. Most of them (aluminium, plastics, iron, electrical wires, etc.) may be disposed of in normal garbage collection bins and can be recycled by disposing of in specific recyclable material collection bins and disposal in authorized centres. Other components (electrical boards, remote control batteries, etc.), however, may contain polluting substances. They should therefore be removed and given to qualified service companies for proper disposal.

Prior to disposal, it is always advisable to check specific regulations in force in the place of disposal.

**PLEASE DISPOSE OF PROPERLY!**

## 12 Manufacturer's warranty



### MANUFACTURER'S DECLARATION OF CONFORMITY

*Pursuant to annex II B of the Machinery Directive 98/37/EC*



CAME Cancelli Automatici S.p.A.  
via Martiri della Libertà, 15  
31030 Dosson di Casier - Treviso - ITALY  
tel (+39) 0422 4940 - fax (+39) 0422 4941  
internet: www.came.it - e-mail: info@came.it

**IMPORTANT WARNING!**

Do not use the equipment specified here above, before completing the full installation  
in full compliance with the Machinery Directive 98/37/EC

Declares under its own responsibility that the equipments for automatic garage doors and gates listed below:

**AUTOMATION FOR STREET BARRIERS  
G4040Z - G4040IZ**

... comply with the National Law related to the following European Directives and to the applicable parts of the following Standards.

98/37/CE - 98/79/CE	MACHINERY DIRECTIVE
98/336/CEE - 92/31/CEE	ELECTROMAGNETIC COMPATIBILITY DIRECTIVE
73/23/CEE - 93/68/CE	LOW VOLTAGE DIRECTIVE
89/106/CEE	CONSTRUCTION PRODUCTS DIRECTIVE

EN 13241-1	EN 12635	EN 61000-6-2
EN 12453	EN 12978	EN 61000-6-3
EN 12445	EN 60335-1	EN 60204-1

MANAGING DIRECTOR  
Mr. Andrea Menuzzo

Reference code to request a true copy of the original: **DDF B EN 6001A**

The data and information provided in this manual are to be considered susceptible to change at any time without warning, by CAME cancelli automatici S.p.A.

**CAME UNITED KINGDOM LTD**  
UNIT 3, ORCHARD BUSINESS PARK TOWN STREET,  
SANDIACRE  
NOTTINGHAM - NG10 5BP - U.K.  
Tel 0044 115 9210430  
Fax 0044 115 9210431

